

GLOBAL  
HEALTH  
SECURITY

E P I D E M I C A L E R T A N D R E S P O N S E



World Health  
Organization



---

# LABORATORY

---

# BIOSAFETY MANUAL

*SECOND EDITION (REVISED)*



---

**WORLD HEALTH ORGANIZATION**

*Geneva 2003*

# interim guidelines

© World Health Organization 2003

This publication is not a formal publication of the World Health Organization (WHO), and all rights are reserved by the Organization. The publication may, however, be freely reviewed, abstracted, reproduced and translated, in part or in whole, but not for sale or for use in conjunction with commercial purposes.

The views expressed in publications by named authors are solely the responsibility of those authors.

The designations employed and the presentation of the material in this publication, including tables and maps, do not imply the expression of any opinion whatsoever on the part of the secretariat of the World Health Organization concerning the legal status of any country, territory, city or area or of its authorities, or concerning the delimitation of its frontiers or boundaries. Dotted lines on maps represent approximate border lines for which there may not yet be full agreement.

The mention of specific companies or of certain manufacturers' products does not imply that they are endorsed or recommended by WHO in preference to others of a similar nature that are not mentioned. Errors and omissions excepted, the names of proprietary products are distinguished by initial capital letters.

# Contents

|  |            |
|--|------------|
| <b>Foreword</b> .....  | <b>v</b>   |
| <b>Acknowledgements</b> .....  | <b>vii</b> |
| <b>1. General principles</b> .....                                     | <b>1</b>   |
| <b>PART I Guidelines</b>   |            |
| <b>2. Risk assessment</b> .....  | <b>7</b>   |
| Specimens for which there is limited information .....                 | 7          |
| Risk assessment and genetically modified microorganisms .....          | 8          |
| <b>3. Basic laboratories – Biosafety Levels 1 and 2</b> .....          | <b>10</b>  |
| Code of practice.....  | 10         |
| Laboratory design and facilities .....                                 | 11         |
| Laboratory equipment.....  | 13         |
| Health and medical surveillance .....                                  | 13         |
| Training .....   | 14         |
| Waste handling .....   | 14         |
| Chemical, fire, electrical and radiation safety .....                  | 16         |
| <b>4. The containment laboratory – Biosafety Level 3</b> .....         | <b>17</b>  |
| Code of practice.....  | 17         |
| Laboratory design and facilities .....                                 | 17         |
| Laboratory equipment.....  | 18         |
| Health and medical surveillance .....                                  | 18         |
| <b>5. The maximum containment laboratory – Biosafety Level 4</b> ..... | <b>20</b>  |
| Laboratory design and facilities .....                                 | 20         |
| Laboratory biosafety manual .....                                      | 21         |
| <b>6. Laboratory animal facilities</b> .....                           | <b>22</b>  |
| Animal facility – Biosafety Level 1 .....                              | 22         |
| Animal facility – Biosafety Level 2 .....                              | 23         |
| Animal facility – Biosafety Level 3 .....                              | 23         |
| Animal facility – Biosafety Level 4 .....                              | 24         |
| Invertebrates .....  | 24         |
| <b>PART II Laboratory equipment</b>                                    |            |
| <b>7. Biological safety cabinets</b> .....                             | <b>29</b>  |
| Class I biological safety cabinet.....                                 | 30         |
| Class II biological safety cabinets.....                               | 30         |
| Class III biological safety cabinet.....                               | 32         |
| Biological safety cabinet air connections .....                        | 33         |
| Selection of a biological safety cabinet.....                          | 33         |
| Using biological safety cabinets in the laboratory.....                | 34         |
| <b>8. Equipment-related hazards</b> .....                              | <b>37</b>  |
| Equipment that may create a hazard.....                                | 37         |

|  |           |
|--|-----------|
| <b>9. Equipment designed to reduce biological hazards.....</b> | <b>39</b> |
| Negative-pressure flexible-film isolators .....                | 40        |
| Pipetting aids .....   | 40        |
| Homogenizers, shakers, blenders and sonicators.....            | 41        |
| Disposable transfer loops .....                                | 41        |
| Microincinerators.....   | 41        |
| Personal protective clothing and equipment.....                | 41        |

### PART III Good microbiological technique

|   |           |
|---|-----------|
| <b>10. Safe laboratory techniques.....</b>                                      | <b>45</b> |
| Safe handling of specimens in the laboratory.....                               | 45        |
| Use of pipettes and pipetting aids.....   | 45        |
| Avoiding the dispersal of infectious materials.....                             | 46        |
| Use of biological safety cabinets .....   | 46        |
| Avoiding ingestion of infectious materials and contact with skin and eyes ..... | 46        |
| Avoiding injection of infectious materials .....                                | 47        |
| Separation of serum .....   | 47        |
| Use of centrifuges .....  | 47        |
| Use of homogenizers, shakers, blenders and sonicators.....                      | 48        |
| Use of tissue grinders .....  | 48        |
| Care and use of refrigerators and freezers.....                                 | 48        |
| Opening of ampoules containing lyophilized infectious materials .....           | 48        |
| Storage of ampoules containing infectious materials .....                       | 49        |
| Special precautions with blood and other body fluids, tissues and excreta ..... | 49        |
| Precautions with materials that may contain prions .....                        | 50        |
| <b>11. Biosafety and recombinant DNA technology.....</b>                        | <b>52</b> |
| Biological expression systems.....  | 52        |
| Properties of the donor organism and cloned DNA.....                            | 52        |
| Viral vectors for gene transfer.....  | 53        |
| Transgenic and “knock-out” animals.....   | 53        |
| Transgenic plants.....  | 53        |
| Conclusions .....   | 53        |
| <b>12. Transport of infectious substances.....</b>                              | <b>55</b> |
| <b>13. Contingency plans and emergency procedures.....</b>                      | <b>56</b> |
| Contingency plan .....  | 56        |
| Emergency procedures for microbiological laboratories.....                      | 56        |
| <b>14. Disinfection and sterilization .....</b>                                 | <b>59</b> |
| Definitions .....   | 59        |
| Precogning and cleaning laboratory materials.....                               | 59        |
| Chemical germicides.....  | 60        |
| Local environmental decontamination .....                                       | 63        |
| Decontamination of biological safety cabinets.....                              | 63        |
| Hand-washing/hand decontamination .....   | 64        |
| Heat disinfection and sterilization .....                                       | 64        |
| Incineration .....  | 66        |
| Disposal .....  | 66        |
| Decontamination of prion-containing materials .....                             | 66        |
| Summary.....  | 66        |

### PART IV Chemical, fire and electrical safety

|                                      |           |
|--------------------------------------|-----------|
| <b>15. Hazardous chemicals .....</b> | <b>69</b> |
| Definitions and classifications..... | 69        |
| Routes of exposure.....              | 69        |
| Storage of chemicals .....           | 69        |

|   |           |
|---|-----------|
| General rules .....   | 70        |
| Toxic effects of chemicals.....   | 70        |
| Explosive chemicals.....  | 72        |
| Chemical spillage.....  | 72        |
| Compressed and liquefied gases .....  | 73        |
| <b>16. Fire in the laboratory .....</b>   | <b>74</b> |
| <b>17. Electrical hazards .....</b>   | <b>75</b> |
| <b>PART V Safety organization and training</b>  |           |
| <b>18. The biosafety officer and safety committee.....</b>                                | <b>77</b> |
| Biosafety officer .....   | 77        |
| Safety committee .....  | 78        |
| General organization.....   | 78        |
| <b>19. Safety rules for support staff.....</b>  | <b>79</b> |
| Engineering and building maintenance services .....                                       | 79        |
| Cleaning (domestic) services.....   | 79        |
| Safety rules for domestic and cleaning staff.....   | 79        |
| <b>20. Training programmes .....</b>  | <b>81</b> |
| Basic course: Good laboratory practice (GLP).....   | 82        |
| Module 1 (the core module): Good microbiological technique (GMT).....                     | 83        |
| Module 2: The safe laboratory environment.....  | 83        |
| Module 3: GLP for support staff.....  | 84        |
| Module 4: GLP for safety staff .....  | 84        |
| Module 5: GLP for specialist staff who handle microorganisms in Risk Groups 3 and 4 ..... | 85        |
| <b>21. Safety checklist.....</b>  | <b>87</b> |
| Laboratory premises .....   | 89        |
| Storage facilities.....   | 89        |
| Sanitation and staff facilities .....   | 89        |
| Heating and ventilation .....   | 89        |
| Lighting .....  | 90        |
| Services .....  | 90        |
| Security .....  | 90        |
| Fire prevention.....  | 90        |
| Flammable liquid storage.....   | 90        |
| Electrical hazards.....   | 91        |
| Compressed and liquefied gases .....  | 91        |
| Personal protection .....   | 91        |
| Health and safety of staff .....  | 91        |
| Laboratory equipment.....   | 92        |
| Infectious materials .....  | 92        |
| Chemicals and radioactive substances .....  | 92        |
| <b>References .....</b>   | <b>94</b> |
| <b>ANNEX 1 Immunization of staff .....</b>  | <b>98</b> |
| <b>ANNEX 2 WHO Biosafety Collaborating Centres.....</b>                                   | <b>99</b> |

interim guidelines

# Foreword

The World Health Organization (WHO) has long recognized that safety and, in particular, biological safety are important international issues. This specialized agency of the United Nations published the first edition of its *Laboratory biosafety manual* in 1983. The manual encourages countries to prepare specific codes of practice for the safe handling of pathogenic microorganisms in laboratories within their geographical borders, and provides expert guidance for developing such codes of practice.

This web-based revision of the second edition is the first step in the preparation of a third edition, planned for publication in 2003. The new publication will combine the *Laboratory biosafety manual, 2nd ed. (revised)* and the contents of the document entitled *Safety in health-care laboratories*<sup>1</sup>.

The authors and editor of this revised second edition continue the now-established WHO tradition of promoting health and safety in microbiological laboratories in the international community. While the technical content affirms the guidance of previous editions, there are helpful changes in the organization of the text and valuable new material is included. The importance of personal responsibility for safe laboratory activities is stressed throughout the manual. A safe and healthful laboratory environment is the product of individuals who are well trained and technically proficient in safe practices, and share responsibility for their own safety and for the safety of their colleagues, their communities and the environment. Personal responsibility also involves the practice of assessing risks prior to the conduct of activities that involve new protocols or new pathogens. Two new chapters address risk assessment and recombinant DNA technology. These timely additions provide thoughtful and concise guidance for assessing risks in the contemporary microbiology laboratory.

A safe and healthful laboratory environment is also the product of responsible institutional leadership. National codes of practice foster and promote good institutional leadership in biosafety. The revised second edition of the WHO *Laboratory biosafety manual* is, like the previous editions, a helpful reference and guide to nations that accept the challenge to develop national codes of practice.

W. Emmett Barkley, PhD  
Director, Office of Laboratory Safety  
Howard Hughes Medical Institute  
Chevy Chase, MD, USA

---

<sup>1</sup> *Safety in health-care laboratories*. Geneva, World Health Organization, 1999 (unpublished document WHO/LAB/97.1). Obtainable on request from Department of Vaccines and Other Biologicals, World Health Organization, 1211 Geneva 27, Switzerland; <http://www.who.int/gpv-documents/>.

interim guidelines



## Acknowledgements

The development of this revised second edition of the *Laboratory biosafety manual* has been made possible through the contributions of the following, whose expertise is gratefully acknowledged:

- Dr Ingegerd Kallings, Swedish Institute of Infectious Disease Control, Stockholm, Sweden
- Ms Mary Ellen Kennedy, Consultant in Biosafety, Ashton, Ontario, Canada (*Technical editor*)
- Ms Margery Kennett, Victorian Infectious Diseases Reference Laboratory, North Melbourne, Australia
- The late Dr Richard Knudsen, Office of Health and Safety, Centers for Disease Control and Prevention, Atlanta, GA, USA
- Dr Nicoletta Previsani, Biosafety Programme, World Health Organization, Geneva, Switzerland
- Dr Jonathan Richmond, Office of Health and Safety, Centers for Disease Control and Prevention, Atlanta, GA, USA
- Dr Syed A. Sattar, Faculty of Medicine, University of Ottawa, Ottawa, Ontario, Canada
- Dr Deborah E. Wilson, Division of Safety, National Institutes of Health, Washington, DC, USA
- Dr Riccardo Wittek, Institute of Animal Biology, University of Lausanne, Lausanne, Switzerland

interim guidelines

interim guidelines

# 1. General principles

Throughout this manual, references are made to the relative hazards of infective microorganisms by risk group (WHO Risk Groups 1, 2, 3 and 4). This risk group classification is to be used for laboratory work only. Laboratories are designated according to their design features, construction and containment facilities as basic – Biosafety Level 1, basic – Biosafety Level 2, containment – Biosafety Level 3 and maximum containment – Biosafety Level 4. Table 1 describes the risk groups, Table 2 relates them to the laboratory designations, and Table 3 summarizes the requirements at the four biosafety levels.

**Table 1. Classification of infective microorganisms by risk group<sup>a</sup>**

---

**Risk Group 1** (no or very low individual and community risk)

A microorganism that is unlikely to cause human or animal disease.

**Risk Group 2** (moderate individual risk, low community risk)

A pathogen that can cause human or animal disease but is unlikely to be a serious hazard to laboratory workers, the community, livestock or the environment. Laboratory exposures may cause serious infection, but effective treatment and preventive measures are available and the risk of spread of infection is limited.

**Risk Group 3** (high individual risk, low community risk)

A pathogen that usually causes serious human or animal disease but does not ordinarily spread from one infected individual to another. Effective treatment and preventive measures are available.

**Risk Group 4** (high individual and community risk)

A pathogen that usually causes serious human or animal disease and that can be readily transmitted from one individual to another, directly or indirectly. Effective treatment and preventive measures are not usually available.

---

<sup>a</sup> The concept and classification of risk groups are being reevaluated and will be addressed in the third edition of the *Laboratory biosafety manual*.

**Table 2. Relation of risk groups to biosafety levels, practices and equipment**

| Risk Group | Biosafety Level           | Laboratory type                               | Laboratory practices                         | Safety equipment                           |
|------------|---------------------------|---|--|--|
| 1          | Basic – Biosafety Level 1 | Basic teaching, research                      | GMT  | None; open bench work                      |
| 2          | Basic – Biosafety Level 2 | Primary health services; diagnostic, research | GMT plus protective clothing, biohazard sign | Open bench plus BSC for potential aerosols |

---

| Risk Group | Biosafety Level                         | Laboratory type              | Laboratory practices  | Safety equipment   |
|------------|---|------------------------------|---|--|
| 3          | Containment – Biosafety Level 3         | Special diagnostic, research | As Level 2 plus special clothing, controlled access, directional air flow | BSC and/or other primary devices for all activities  |
| 4          | Maximum containment – Biosafety Level 4 | Dangerous pathogen units     | As Level 3 plus airlock entry, shower exit, special waste disposal        | Class III BSC, or positive pressure suits in conjunction with Class II BSCs, double-ended autoclave (through the wall), filtered air |

BSC, biological safety cabinet; GMT, good microbiological technique

Countries (regions) should draw up a national (regional) classification of microorganisms, by risk group, based on the following factors.

- Pathogenicity of the organism.
- Mode of transmission and host range of the organism. These may be influenced by existing levels of immunity in the local population, density and movement of the host population, presence of appropriate vectors, and standards of environmental hygiene.
- Local availability of effective preventive measures. These may include: prophylaxis by immunization or administration of antisera (passive immunization); sanitary measures, e.g. food and water hygiene; control of animal reservoirs or arthropod vectors.
- Local availability of effective treatment. This includes passive immunization, postexposure vaccination, and use of antimicrobials, antivirals and chemotherapeutic agents, and should take into consideration the possibility of the emergence of drug resistant strains.

**Table 3. Summary of biosafety level requirements**

|                                   | Biosafety level |           |           |     |
|-----------------------------------|-----------------|-----------|-----------|-----|
|                                   | 1               | 2         | 3         | 4   |
| Isolation of laboratory           | No              | No        | Desirable | Yes |
| Room sealable for decontamination | No              | No        | Yes       | Yes |
| Ventilation:                      |                 |           |           |     |
| – inward air flow                 | No              | Desirable | Yes       | Yes |
| – mechanical via building system  | No              | Desirable | Yes       | No  |
| – mechanical, independent         | No              | Desirable | Yes       | Yes |
| – HEPA filtered air exhaust       | No              | No        | Desirable | Yes |
| Double-door entry                 | No              | No        | Yes       | Yes |
| Airlock                           | No              | No        | No        | Yes |
| Airlock with shower               | No              | No        | No        | Yes |
| Anteroom                          | No              | No        | Yes       | No  |
| Anteroom with shower              | No              | No        | Desirable | No  |
| Effluent treatment                | No              | No        | Desirable | Yes |

|                             | <b>Biosafety level</b> |           |           |   |
|-----------------------------|------------------------|-----------|-----------|---|
|                             | <b>1</b>               | <b>2</b>  | <b>3</b>  | <b>4</b>                                      |
| Autoclave:                  |                        |           |           |   |
| – on site                   | Yes                    | Yes       | Yes       | Yes   |
| – in laboratory room        | No                     | No        | Desirable | Yes   |
| – double-ended              | No                     | No        | Desirable | Yes   |
| Biological safety cabinets: |                        |           |           |   |
| – Class I                   | No                     | Optional  | Yes       | No  |
| – Class II                  | No                     | Desirable | Yes       | Yes, in conjunction with suit laboratories    |
| – Class III                 | No                     | No        | Desirable | Yes, in conjunction with cabinet laboratories |

In assessing the various criteria for classification, it is important to take into account conditions prevailing in the geographical area in which the microorganisms are handled.

In the preparation of classification lists it is recommended that, where appropriate, some additional information is given about the advisability of the use of personal protective equipment and primary containment devices (e.g. biological safety cabinets). Consideration must also be given to enhancing biosafety practices and procedures and general containment levels for organisms known to be multidrug-resistant and in cases where high volumes or concentrations of an agent may be used. Examples of classification lists are available from the Centers for Disease Control and Prevention (CDC) and the National Institute of Health (NIH), USA (1), and the European Union (EU) (2).

interim guidelines

# PART I

## Guidelines

interim guidelines

interim guidelines



## 2. Risk assessment

The backbone of the practice of biosafety is risk assessment. While there are many tools available to assist in the assessment of risk for a given procedure or experiment, the most important component is professional judgement. Risk assessments should be performed by the individuals most familiar with the specific characteristics of the organisms being considered for use, the equipment and procedures to be employed, animal models that may be used, and the containment equipment and facilities available. The laboratory director or principal investigator is responsible for ensuring that adequate and timely risk assessments are performed and for working closely with the institution's safety committee (if existing) and biosafety personnel (if existing) to ensure that appropriate equipment and facilities are available to support the work being considered. Once performed, risk assessments should be routinely reviewed and revised when necessary, taking into consideration acquisition of new data having a bearing on the degree of risk and other relevant new information from the scientific literature.

One of the most helpful tools available for performing a microbiological risk assessment is the listing of risk groups for microbiological agents (see Chapter 1). However, simple reference to the risk grouping for a particular agent is insufficient in the conduct of a risk assessment. Other factors that should be considered, as appropriate, include:

- pathogenicity of the agent and infectious dose
- consideration of the outcome of exposure
- natural route of infection
- other routes of infection, resulting from laboratory manipulations (parenteral, airborne, ingestion)
- stability of the agent in the environment
- concentration of the agent and volume of concentrated material to be manipulated
- presence of a suitable host (human or animal)
- information available from animal studies and reports of laboratory-acquired infections or clinical reports
- laboratory activity planned (concentration, sonication, aerosolization, centrifugation, etc.)
- any genetic manipulation of the organism that may extend the host range of the agent or alter the agent's sensitivity to known, effective treatment regimens (see Risk assessment and genetically modified microorganisms, below)
- local availability of effective prophylaxis or therapeutic interventions.

On the basis of the information ascertained during the risk assessment, a biosafety level can be assigned to the planned work and appropriate personal protective equipment selected.

### **Specimens for which there is limited information**

The risk assessment procedure described above works well when there is adequate information available. However, there are situations when the information is insufficient to perform an appropriate risk assessment, for example, with clinical specimens or epidemiological samples collected in the field. In these cases, it is prudent to take a conservative approach to specimen manipulation.

- Universal precautions (3) should always be followed, and barrier protections applied (gloves, gowns, eye protection), regardless of the origin of the samples.
- Basic containment – Biosafety Level 2 should be the minimum requirement for the handling of specimens.
- Transport of specimens should follow national and/or international rules and regulations.

Some information may be available to assist in determining the risk of handling these specimens:

- medical data on the patient

- . epidemiological data (morbidity and mortality data, suspected route of transmission, other outbreak investigation data)
- . information on the geographical origin of the specimen.

## **Risk assessment and genetically modified microorganisms**

Risk assessment for work with genetically modified microorganisms (GMMOs) must include an assessment of the degree of potential harm that may arise, the severity of consequence, and the likelihood or frequency of that harm occurring. It must be suitable and sufficient; it need not necessarily be very detailed. It may be simple, for example, where it is immediately obvious that the risks are low or that the proposed control measures are clearly adequate. For an operation involving a low-hazard, well-known and well-understood organism, it may be possible to determine the outcome of the assessment almost at first glance. However, for a complex operation involving more hazardous organisms about which there may be some degree of uncertainty, the assessment will have to be extensive and may necessitate the acquisition of new data.

Potential hazards (harmful effects) of work involving GMMOs may be associated with the primary recipient or host organism, other potential recipients in the environment, or the donor microorganism. In many cases, the characteristics of the host organism will be more relevant to the risk assessment than those of the donor organism. Factors to consider during hazard identification include pathogenicity, the biological activity or toxicity of the foreign gene product, and the mobility of plasmid or viral vectors. As a general guide, if a donor organism is used only as a source of well-characterized DNA for a selectable phenotype (e.g. kanamycin resistance or  $\beta$ -galactosidase activity) or a promoter or other control sequence, the characteristics of the donor will not need to be considered. If, however, the insert contains genes that encode biologically active molecules, toxins or virulence factors, then relevant information from the donor organism should be considered.

### ***Hazards associated with the host/recipient***

Consideration should be given to:

- . susceptibility of the host
- . pathogenicity of the host strain, including virulence, infectivity, toxin production and modification of the host range
- . degree of immunity of the recipient and status of immune system
- . seriousness of the consequences of exposure.

### ***Hazards arising directly from the inserted gene***

Assessment is necessary in situations where the product of the inserted gene has known biologically active properties that may give rise to harm, for example:

- . toxins
- . cytokines
- . hormones
- . gene expression regulators
- . virulence factors or enhancers
- . antibiotic resistances
- . allergens.

The consideration of such cases should include an estimation of the level of expression required to achieve biological activity.

### ***Hazards arising from the alteration of existing pathogenic traits***

Many modifications do not involve genes whose products are inherently harmful but adverse effects may arise as the result of alteration of existing non-pathogenic or pathogenic traits. Modification of normal genes may alter pathogenicity. In an attempt to identify these potential hazards, the following points may be considered (the list is not exhaustive).

- . Is there an increase in infectivity or pathogenicity?
- . Could any disabling mutation within the recipient be overcome as a result of the insertion of the foreign gene?
- . Does the foreign gene encode a pathogenicity determinant from another organism (bacterial toxins, invasins, integrins and surface structures such as membrane glycoproteins and lipopolysaccharides)?
- . If the foreign DNA does include a pathogenicity determinant, is it foreseeable that this gene could contribute to the pathogenicity of the GMMO?
- . Is treatment available?
- . Will the susceptibility of the GMMO to antibiotics or other forms of therapy be affected as a consequence of the genetic modification?
- . Is eradication of the GMMO achievable?

Other factors that need to be considered in the GMMO risk assessment are the presence of any potentially oncogenic gene sequences and potential hazards associated with the cell lines being used, such as the presence of adventitious agents. The introduction of whole animals or plants into an experiment also requires careful consideration. The investigator must be familiar and comply with the regulations, restrictions and requirements for the conduct of work with GMMOs at his or her institution.

For further information see Chapter 11, and references 4 and 5.

### 3. Basic laboratories – Biosafety Levels 1 and 2

For the purposes of this manual, the guidance and recommendations given as minimum requirements pertaining to laboratories of all biosafety levels are directed at microorganisms in Risk Groups 1–4. Although some of the precautions may appear to be unnecessary for some organisms in Risk Group 1, they are desirable for training purposes to promote good (i.e. safe) microbiological techniques.

Diagnostic and health care laboratories (public health, clinical or hospital-based) must all be designed for Biosafety Level 2 or above. As no laboratory has complete control over the specimens it receives, laboratory workers may occasionally and unexpectedly be exposed to organisms in higher risk groups than anticipated. This possibility must be recognized in the development of safety plans and policies. In some countries, accreditation of clinical laboratories is required. Globally, universal precautions (3) should always be adopted and practised.

The guidelines for basic laboratories – Biosafety Levels 1 and 2 presented here are comprehensive and detailed, as they are fundamental to all levels of laboratories. The guidelines for containment laboratories – Biosafety Level 3 and maximum containment laboratories – Biosafety Level 4 that follow (Chapters 4 and 5) are modifications of and additions to these guidelines, designed for work with the more dangerous (hazardous) pathogens.

#### **Code of practice**

This code is a listing of the most essential laboratory practices and procedures that are basic to good microbiological techniques. In many laboratories and national laboratory programmes, this code may be used to develop written practices and procedures for safe laboratory operations.

Each laboratory should adopt a “safety or operations manual” that identifies known and potential hazards, and specifies practices and procedures to eliminate or minimize such hazards. Good microbiological technique is fundamental to laboratory safety. Specialized laboratory equipment is a supplement to but can never replace appropriate procedures. The most important concepts are listed below.

#### **Access**

1. The international biohazard warning symbol and sign (Fig. 1) must be displayed on the doors of the rooms where microorganisms of Risk Group 2 or higher risk groups are handled.
2. Only authorized persons should be allowed to enter the laboratory working areas.
3. Laboratory doors should be kept closed.
4. Children under the age of 16 years should not be authorized or allowed to enter laboratory working areas.
5. Access to animal houses should be specially authorized.
6. Animals not involved in the work of the laboratory should not be permitted in the laboratory.
7. “No smoking” “No eating” and “No drinking” signs should be displayed clearly inside and outside the laboratory.

#### **Personal protection**

1. Laboratory coveralls, gowns or uniforms must be worn at all times for work in the laboratory.
2. Appropriate gloves must be worn for all procedures that may involve direct or accidental contact with blood, infectious materials or infected animals. After use, gloves should be removed aseptically and hands must then be washed.
3. Personnel must wash their hands after handling infectious materials and animals, and before they leave the laboratory working areas.

4. Safety glasses, face shields (visors) or other protective devices must be worn when it is necessary to protect the eyes and face from splashes, impacting objects and sources of artificial ultraviolet radiation.
5. It is prohibited to wear protective laboratory clothing outside of the laboratory, e.g. in canteens, coffee rooms, offices, libraries, staff rooms and toilets.
6. Open-toed footwear should not be worn in laboratories.
7. Eating, drinking, applying cosmetics and handling contact lenses is prohibited in the laboratory working areas.
8. Storing human foods or drinks anywhere in the laboratory working areas is prohibited.
9. Protective laboratory clothing should not be stored in the same lockers or cupboards as street clothing.

### **Procedures**

1. Pipetting by mouth must be strictly forbidden.
2. Materials must not be placed in the mouth. Labels must not be licked.
3. All technical procedures should be performed in a way that minimizes the formation of aerosols and droplets. Whenever there is an increased risk of aerosolization, work should be conducted in a biological safety cabinet.
4. The use of hypodermic needles and syringes should be limited. They must not be used as substitutes for pipetting devices or for any purpose other than parenteral injection or aspiration of fluids from laboratory animals.
5. All spills, accidents and overt or potential exposures to infectious materials must be reported to the laboratory supervisor. A written record of such accidents and incidents should be maintained.
6. A written procedure for the clean up of all spills must be developed and followed.

### **Laboratory working areas**

1. The laboratory should be kept neat, clean and free of materials that are not pertinent to the work.
2. Work surfaces must be decontaminated after any spill of potentially dangerous material and at the end of the working day.
3. All contaminated materials, specimens and cultures must be decontaminated before disposal or cleaning for reuse.
4. Packing and transportation must follow applicable national and/or international regulations.
5. When windows can be opened, they should be fitted with arthropod-proof screens.

### **Biosafety management**

1. It is the responsibility of the laboratory director (the person who has immediate responsibility for the laboratory) to ensure the development and adoption of a biosafety management plan and a safety or operations manual.
2. The laboratory supervisor (reporting to the laboratory director) should ensure that regular training in laboratory safety is provided.
3. Personnel should be advised of special hazards and required to read the safety or operations manual and follow standard practices and procedures. The laboratory supervisor should make sure that all personnel understand these. A copy of the safety or operations manual should be available in the laboratory.
4. When appropriate, there should be an arthropod and rodent control programme.
5. Appropriate medical evaluation, surveillance and treatment should be provided for all personnel in case of need, and adequate medical records should be maintained.
6. Baseline serum samples may be collected from laboratory staff and other persons at risk. These should be stored appropriately according to national or local guidelines. Additional specimens may be collected periodically depending on the organisms handled and the function of the laboratory.

### **Laboratory design and facilities**

In designing a laboratory and assigning certain types of work to it, special attention should be paid to conditions that are known to pose safety problems. These include:

- formation of aerosols
- work with large volumes and/or high concentrations of microorganisms
- overcrowding and too much equipment
- infestation with rodents and arthropods
- unauthorized entrance
- workflow: use of specific samples and reagents.

### **Design features**

1. Ample space must be provided for the safe conduct of laboratory work and for cleaning and maintenance.
2. Walls, ceilings and floors should be smooth, easy to clean, impermeable to liquids and resistant to the chemicals and disinfectants normally used in the laboratory. Floors should be slip-resistant. Exposed pipes and ducting should be avoided where possible.
3. Bench tops should be sealed to the walls, impervious to water and resistant to disinfectants, acids, alkalis, organic solvents and moderate heat.
4. Illumination should be adequate for all activities. Undesirable reflections and glare should be avoided.
5. Laboratory furniture should be sturdy. Open spaces between and under benches, cabinets and equipment should be accessible for cleaning.
6. Storage space must be adequate to hold supplies for immediate use and thus prevent clutter on bench tops and in aisles. Additional long-term storage space, conveniently located outside the laboratory working areas, should also be provided.
7. Space and facilities should be provided for the safe handling and storage of solvents, radioactive materials, and compressed and liquefied gases.
8. Facilities for storing outer garments and personal items should be provided outside the laboratory working areas.
9. Facilities for eating and drinking and for rest should be provided outside the laboratory working areas.
10. Hand-wash basins, with running water if possible, should be provided in each laboratory room, preferably near the exit door.
11. Doors should have vision panels, be self-closing and have appropriate fire ratings.
12. An autoclave should be available in the same building as the laboratory.
13. Safety systems should cover fire, electrical emergencies, emergency shower and eyewash facilities.
14. First-aid areas or rooms suitably equipped and readily accessible should be available.
15. There are no specific ventilation requirements for laboratories handling Risk Group 1 and 2 microorganisms. However, in the planning of new facilities, consideration should be given to the provision of mechanical ventilation systems that provide an inward flow of air without recirculation. If there is no mechanical ventilation, windows should be able to be opened and should be fitted with arthropod-proof screens.
16. A dependable supply of good quality water is essential. There should be no cross-connections between sources of laboratory and drinking-water supplies. An anti-backflow device should protect the public water system.
17. There should be a reliable and adequate electricity supply and emergency lighting to permit safe exit. A stand-by generator is desirable for the support of essential equipment, such as incubators, biological safety cabinets, freezers, etc., and for the ventilation of animal cages.
18. There should be a reliable and adequate supply of gas. Good maintenance of the installation is mandatory.
19. Three aspects of waste disposal need special attention to meet performance and pollution-control requirements:
  - autoclaves for the treatment of solid waste need specially designed accommodation and services
  - incinerators should be of special design, equipped with afterburners and smoke-consuming devices
  - contaminated wastewater must be decontaminated.
20. Laboratories and animal houses are occasionally the targets of vandals. Physical and fire security must be considered. Strong doors, screened windows, and restricted issue of keys are compulsory. Other measures should be considered and applied, as appropriate, to augment security.

## Laboratory equipment

Together with good procedures and practices, the use of safety equipment will help to reduce risks when dealing with biosafety hazards. This section deals with basic principles related to equipment suitable for laboratories of all biosafety levels. Requirements for laboratory equipment pertinent to higher biosafety levels are dealt with in the relevant chapters.

The laboratory director should, after consultation with the biosafety officer and safety committee (if designated), ensure that adequate equipment is provided and that it is used properly. Equipment should be selected to take account of certain general principles, i.e. it should be:

- designed to prevent or limit contact between the operator and the infectious material
- constructed of materials that are impermeable to liquids, resistant to corrosion and meet structural requirements
- fabricated to be free of burrs, sharp edges and unguarded moving parts
- designed, constructed and installed to facilitate simple operation and provide for ease of maintenance, cleaning, decontamination and certification testing; glassware and other breakable materials should be avoided, whenever possible.

Detailed performance and construction specifications may need to be consulted to ensure that the equipment possesses the necessary safety features.

### **Essential biosafety equipment**

1. Pipetting aids – to avoid mouth pipetting. Many different designs are available.
2. Biological safety cabinets, to be used whenever:
  - infectious materials are handled; such materials may be centrifuged in the open laboratory if sealed centrifuge safety cups are used and if they are loaded and unloaded in a biological safety cabinet
  - there is an increased risk of airborne infection
  - procedures with a high potential for producing aerosols are used; these may include centrifugation, grinding, blending, vigorous shaking or mixing, sonic disruption, opening of containers of infectious materials whose internal pressure may be different from the ambient pressure, intranasal inoculation of animals, and harvesting of infectious tissues from animals and eggs.
3. Plastic disposable transfer loops. Alternatively, electric transfer loop incinerators may be used inside the biological safety cabinet (BSC) to reduce aerosol production.
4. Screw-capped tubes and bottles.
5. Autoclaves to decontaminate infectious materials.
6. Plastic disposable Pasteur pipettes, whenever available, to avoid glass.
7. Equipment such as autoclaves and biological safety cabinets must be validated with appropriate methods (usually by a certified examiner) before being taken into use. Recertification should take place at regular intervals, according to the manufacturer's instructions.

## Health and medical surveillance

The employing authority, through the laboratory director, is responsible for ensuring that there is adequate surveillance of the health of laboratory personnel. The objective of such surveillance is to monitor for occupationally acquired diseases. Appropriate activities to achieve these objectives are to:

- provide active or passive immunization where indicated (see Annex 1)
- facilitate the early detection of laboratory-acquired infections
- exclude highly susceptible individuals (such as pregnant women) from highly hazardous laboratory work
- provide effective personal protective equipment and procedures.

### **Guidelines for the surveillance of laboratory workers handling microorganisms in Risk**

#### **Group 1**

Historical evidence indicates that these microorganisms are unlikely to cause human disease or animal disease of veterinary importance. Ideally, however, all laboratory workers should undergo a pre-

employment health check at which their medical history is recorded. Prompt reporting of illnesses or laboratory accidents is desirable and all staff members should be made aware of the importance of maintaining good microbiological techniques.

### ***Guidelines for the surveillance of laboratory workers handling microorganisms in Risk***

#### **Group 2**

1. A pre-employment or preplacement health check is necessary. The person's medical history should be recorded and a clinical examination and collection of baseline serum sample are recommended.
2. Records of illness and absence should be kept by the laboratory management; it is the responsibility of the laboratory worker and his or her own medical adviser to keep the laboratory director informed of all absences due to illness.
3. Women of childbearing age should be made aware of the risk to an unborn child of occupational exposure to certain microorganisms, e.g. rubella virus. The precise steps taken to protect the fetus will vary, depending on the microorganisms to which the women may be exposed.

### **Training**

Human error and poor technique can compromise the best of safeguards to protect the laboratory worker. Thus, a safety-conscious staff, well informed about the recognition and control of laboratory hazards, is key to the prevention of laboratory-acquired infections, incidents and accidents. For this reason, continuous in-service training in safety measures is essential. An effective safety programme begins with the laboratory managers, who should ensure that safe laboratory practices and procedures are integrated into the basic training of employees. Training in safety measures should be an integral part of new employees' introduction to the laboratory. Employees should be introduced to the code of practice and to local guidelines. Measures to assure that employees have read and understood the guidelines, such as signature pages, should be adopted. Laboratory supervisors play the key role in training their immediate staff in good laboratory techniques. The biosafety officer can assist in training and with the development of training aids and documentation.

Staff training should always include safe methods for dealing with the following highly hazardous procedures that are commonly encountered by all laboratory personnel, involving:

- inhalation risks (i.e. aerosol production), such as using loops, streaking agar plates, pipetting, making smears, opening cultures, taking blood/serum samples, centrifugation
- ingestion risks, such as handling specimens, smears and cultures
- risks of percutaneous exposures, through the use of syringe and needle techniques
- animal handling that may result in bites and scratches
- handling of blood and other potentially hazardous pathological materials
- decontamination and disposal of infectious material.

### **Waste handling**

Waste is anything that is to be discarded.

In laboratories, decontamination of wastes and their ultimate disposal are closely interrelated. In terms of daily use, few if any contaminated materials will require actual removal from the laboratory or destruction. Most glassware, instruments and laboratory clothing will be reused or recycled. The overriding principle is that all infectious materials should be decontaminated, autoclaved or incinerated within the laboratory.

The principal questions to be asked before discharge of any objects or materials from laboratories that deal with potentially infectious microorganisms or animal tissues are as follows.

1. Have the objects or materials been effectively decontaminated or disinfected by an approved procedure?
2. If not, have they been packaged in an approved manner for immediate on-site incineration or transfer to another facility with incineration capacity?
3. Does the disposal of the decontaminated objects or materials involve any additional potential hazards, biological or otherwise, to those who carry out the immediate disposal procedures or who might come into contact with discarded items outside the facility?



## **Decontamination**

Steam autoclaving is the preferred method for all decontamination processes. Materials for decontamination and disposal should be placed in containers, e.g. autoclavable plastic bags that are colour-coded according to whether the contents are to be autoclaved and/or incinerated. Alternative methods may be envisaged only if they remove and/or kill microorganisms (for more details see Chapter 14).

## **Disinfectants and chemicals**

The safety or operations manual should include a written policy stating which disinfectants are to be used for what purposes, and the manufacturer's recommended dilution for each disinfectant. The manufacturer should be able to provide relevant documentation. Make sure each disinfectant has been validated for its indicated use in the laboratory.

Sodium hypochlorite and phenolic compounds are the disinfectants recommended for general laboratory use.

For special purposes, various surface-active or lipid-destroying agents, including alcohols, iodine, iodophors and other oxidizing agents, as well as a very high or extremely low pH, can be effective, provided that it has been established that the agent to be destroyed is not resistant to the procedure.

## **Other methods**

The use of dry heat is discouraged because of its unpredictable variation. Similarly, microwave, ultraviolet and ionizing radiation are unsuitable.

New technologies, including alkaline hydrolysis, may be used as a substitute for incineration for terminal infectious waste treatment.

## **Waste handling and disposal procedures**

An identification and separation system for infectious materials and their containers should be adopted. Categories should include the following.

1. Non-contaminated (non-infectious) waste that can be reused or recycled or disposed of as general, "household" waste.
2. Contaminated (infectious) "sharps" – hypodermic needles, scalpels, knives and broken glass; these should always be collected in puncture-proof containers fitted with covers and treated as infectious.
3. Contaminated material for decontamination by autoclaving and thereafter washing and reuse or recycling.
4. Contaminated material for autoclaving and disposal.
5. Contaminated material for direct incineration.

## **Sharps**

After use, hypodermic needles should not be recapped, clipped or removed from disposable syringes. The complete assembly should be placed in a sharps container. Sharps containers must be puncture proof and not be filled to capacity. When they are three-quarters full they should be placed in "infectious waste" containers and incinerated, with prior autoclaving if laboratory practice requires it. Sharps containers must not be disposed of in landfills.

Disposable syringes, used alone or with needles, should be placed in containers and incinerated, with prior autoclaving if required.

## **Contaminated (infectious) materials for autoclaving and reuse**

No precleaning should be attempted of any contaminated (infectious) materials to be autoclaved and reused. Any necessary cleaning or repair must be done only after autoclaving or disinfection.

### *Contaminated (infectious) materials for disposal*

Apart from sharps, which are dealt with above, all contaminated (potentially infectious) materials should be autoclaved in leakproof containers, e.g. autoclavable, colour-coded plastic bags, before disposal. After autoclaving, the material may be placed in transfer containers for transport to the incinerator. If possible, materials deriving from health care activities should not be discarded in landfills even after decontamination. If an incinerator is available on the laboratory site, autoclaving may be omitted: the contaminated waste should be placed in designated containers (e.g. colour-coded bags) and transported directly to the autoclave or incinerator. Reusable transfer containers should be leakproof and have tight-fitting covers. They should be disinfected and cleaned before they are returned to the laboratory for further use.

Discard pots, pans or jars, preferably unbreakable (e.g. plastic), and containing a suitable disinfectant, freshly prepared each day, should be placed at every work station. Waste materials should remain in intimate contact with the disinfectant (i.e. not protected by air bubbles) for the appropriate time, according to the disinfectant used (see Chapter 14). The disinfectant should then be poured into a container for autoclaving or incineration. The discard pots should be autoclaved and washed before reuse.

Incineration is the method of choice for the final disposal of contaminated waste, including carcasses of laboratory animals (see section on Incineration in Chapter 14). Incineration of contaminated waste must meet with the approval of the public health and air pollution authorities, as well as that of the laboratory biosafety officer.

### **Chemical, fire, electrical and radiation safety**

A breakdown in the containment of pathogenic organisms may be the indirect result of chemical, fire, electrical or radiation accidents. It is therefore essential to maintain high standards of safety in these fields in any microbiological laboratory. Statutory rules and regulations for each of these will normally be laid down by the competent national or local authority, whose assistance should be sought if necessary. Chemical, fire and electrical hazards are considered in greater detail in Part IV of this manual (Chapters 15–17).

## 4. The containment laboratory – Biosafety Level 3

The containment laboratory – Biosafety Level 3 is designed and provided for work with Risk Group 3 microorganisms and with large volumes or high concentrations of Risk Group 2 microorganisms that pose an increased risk of aerosol spread. Biosafety Level 3 containment requires the strengthening of the operational and safety programmes above those for basic laboratories – Biosafety Levels 1 and 2 (set out in Chapter 3).

The guidelines given in this chapter are presented in the form of additions to those for basic laboratories – Biosafety Levels 1 and 2, which must therefore be applied before those specific for the containment laboratory – Biosafety Level 3. The major additions and changes are in the following:

- . code of practice
- . laboratory design and facilities
- . health and medical surveillance.

Laboratories in this category should be registered or listed with the national or other appropriate health authorities.

### Code of practice

The code of practice for basic laboratories – Biosafety Levels 1 and 2 applies except where modified as follows.

1. The two-person rule should apply, whereby no individual ever works alone in the laboratory.
2. The international biohazard warning symbol and sign (see Fig. 1) displayed on laboratory access doors must identify the microorganism(s) handled and the name of the laboratory supervisor who controls access, and indicate any special conditions for entry into the area, e.g. immunization.
3. Laboratory protective clothing must be of the type with solid-front or wrap-around gowns, scrub suits, coveralls, head covering and, where appropriate, shoe covers or dedicated shoes. Front-buttoned standard laboratory coats are unsuitable. Laboratory protective clothing must not be worn outside the laboratory, and it must be decontaminated before it is laundered.
4. When appropriate, respiratory equipment must be worn in rooms containing infected animals.

### Laboratory design and facilities

The containment laboratory – Biosafety Level 3 is designed for work with Risk Group 3 microorganisms and with large volumes and high concentrations of Risk Group 2 microorganisms, where there is a high risk of aerosol spread and subsequent life-threatening consequences from infection.

The laboratory design and facilities for basic laboratories – Biosafety Levels 1 and 2 apply except where modified as follows.

1. The laboratory should be separated from the areas that are open to unrestricted traffic flow within the building. Additional separation may be achieved by placing the laboratory at the blind end of a corridor, or constructing a partition and door or access through an anteroom or basic laboratory – Biosafety Level 2.
2. Entry for personnel must be through a vestibule (i.e. double-door entry).
3. Access to the laboratory area must be designed to prevent entrance of arthropods and other vermin.
4. Access doors must be self-closing and interlockable. A break-through panel may be provided for emergency exit use.
5. The surfaces of walls, floors and ceilings should be water-resistant and easy to clean. Openings in these surfaces (e.g. for service pipes) should be sealed to facilitate decontamination of the room(s).

6. The laboratory room must be sealable for decontamination. Air-ducting systems must be constructed to permit gaseous decontamination.
7. Windows must be closed, sealed and break-resistant.
8. A foot- or elbow-operated or automatically controlled water source at the hand-wash basin should be provided near to each exit door.
9. There must be a ventilation system that establishes a directional air flow from access spaces into the laboratory room. Staff must at all times ensure that proper directional air flow into the laboratory room is maintained.
10. The building ventilation system must be so constructed that air from the containment laboratory – Biosafety Level 3 is not recirculated to other areas within the building. Air may be HEPA filtered, reconditioned and recirculated within that laboratory. Exhaust air from the laboratory (other than from biological safety cabinets) must be discharged to the outside of the building, so that it is dispersed away from occupied buildings and air intakes. It is recommended that this air is discharged through high-efficiency particulate air (HEPA) filters.
11. Biological safety cabinets should be sited away from walking areas and out of cross-currents from doors and ventilation systems (see Chapter 7).
12. The exhaust air from Class I or Class II biological safety cabinets (see Chapter 7), which will have been passed through HEPA filters, must be discharged in such a way as to avoid interference with the air balance of the cabinet or the building exhaust system. All HEPA filters must be installed in a manner that permits gaseous decontamination and testing.
13. An autoclave for the decontamination of contaminated waste material should be available in the containment laboratory. If infectious wastes have to be transported out of the containment laboratory for disposal, they must be transported in sealed, unbreakable and leakproof containers according to national or international regulations, as appropriate.
14. Anti-backflow devices must be fitted to the water supply.
15. Effluents should be decontaminated before being discharged to the sanitary sewer.

## Laboratory equipment

The principles for the selection of equipment, including biological safety cabinets (see Chapter 7), are the same as for the basic laboratory – Biosafety Level 2, except that activities involving infectious materials are conducted in biological safety cabinets whenever possible, together with other physical containment devices, or special personal protective equipment. While Class I or Class II biological safety cabinets are normally used in the containment laboratory – Biosafety Level 3, a Class III biological safety cabinet may be needed for high-risk procedures involving Risk Group 3 microorganisms, in accordance with local national rules.

## Health and medical surveillance

The objectives of health and medical surveillance programmes for basic laboratories – Biosafety Levels 1 and 2 also apply to containment laboratories – Biosafety Level 3, except where modified as follows.

1. Medical examination of all laboratory personnel who work in Biosafety Level 3 containment laboratories is mandatory. This should include recording of a detailed medical history and a physical examination.
2. A baseline serum sample should be obtained and stored for future reference.
3. Individuals who are immunocompromised should not be employed in facilities with Biosafety Level 3 containment laboratories.
4. Special consideration should be given to the employment of pregnant women (see section on Guidelines for the surveillance of laboratory workers handling microorganisms in Risk Group 2 in Chapter 3).
5. After a satisfactory clinical assessment, the examinee should be provided with a medical contact card (Fig. 2) stating that he or she is employed in a facility with a containment laboratory – Biosafety Level 3. It is suggested that this card should include a picture of the card holder, should be wallet-sized and should always be carried by the holder.

**Note.** The name(s) of the contact persons to be entered will need to be agreed locally but might include the laboratory director, medical adviser and/or biosafety officer.

## A. Front of card

|  |      |                       |
|--|------|-----------------------|
| ILLNESS SURVEILLANCE NOTICE  |      | Card holder's picture |
| Name _____   |      |                       |
| TO THE EMPLOYEE  |      |                       |
| Keep this card in your possession. In case of unexplained febrile illness, present the card to your physician and notify one of the following in the order listed. |      |                       |
| _____  |      |                       |
|  | Work |                       |
| Dr   | Home |                       |
| _____  |      |                       |
|  | Work |                       |
| Dr   | Home |                       |
| _____  |      |                       |

## B. Back of card

|  |
|--|
| TO THE PHYSICIAN   |
| The holder of this card works in an area at _____  |
| in which pathogenic viruses, rickettsia, bacteria, protozoa or helminths are present. In the event of an unexplained febrile illness, please call the employer for information on agents to which this employee may have been exposed. |
| Name of laboratory: _____  |
| Address: _____   |
| _____  |
| _____  |
| Tel: _____   |

Fig. 2. Suggested format for medical contact card

## 5. The maximum containment laboratory – Biosafety Level 4

The maximum containment laboratory – Biosafety Level 4 is designed for work with Risk Group 4 microorganisms. Before such a laboratory is constructed and put into operation, intensive consultations should be held with institutions that have had experience of operating a similar facility. Operational maximum containment laboratories – Biosafety Level 4 should be under the control of national or other appropriate health authorities.

### Laboratory design and facilities

The features of a containment laboratory – Biosafety Level 3 also apply to a maximum containment laboratory – Biosafety Level 4 with the addition of the following.

1. Primary containment. An efficient primary containment system must be in place, consisting of one or a combination of the following.
  - Class III cabinet laboratory. Passage through a minimum of two doors prior to entering the rooms containing the Class III biological safety cabinet (cabinet room) is required. In this laboratory configuration the Class III biological safety cabinet provides the primary containment. A personnel shower with inner and outer changing rooms is necessary. Supplies and materials that are not brought into the cabinet room through the changing area are introduced through a double-door autoclave or fumigation chamber. Once the outer door is securely closed, staff inside the laboratory can open the inner door to retrieve the materials. The doors of the autoclave or fumigation chamber are interlocked in such a way that the outer door cannot open unless the autoclave has been operated through a sterilization cycle or the fumigation chamber has been decontaminated (see Chapter 7)
  - Suit laboratory. A protective suit laboratory with self-contained breathing apparatus differs significantly in design and facility requirements from a Biosafety Level 4 laboratory with Class III biological safety cabinets. The rooms in the protective suit laboratory are arranged to direct personnel through the changing and decontamination areas prior to entering areas where infectious materials are manipulated. In this laboratory configuration, the suit area itself is considered to constitute the primary containment. The suit area is designed and maintained to provide personnel protection equivalent to that provided by Class III biological safety cabinets. A suit decontamination shower must be provided for personnel leaving the containment laboratory area. A separate personnel shower with inner and outer changing rooms is also provided. Personnel who enter the suit area are required to don a one-piece, positively pressurized, HEPA-filter-supplied air suit. Air to the suit must be provided by a system that has a 100% redundant capability with an independent source of air, for use in the event of an emergency. Entry into the suit laboratory is through an airlock fitted with airtight doors. An appropriate warning system for personnel working in the suit laboratory must be provided for use in the event of mechanical system or air failure (see Chapter 7).
2. Controlled access. The maximum containment laboratory – Biosafety Level 4 must be located in a separate building or in a clearly delineated zone within a secure building. Entry and exit of personnel and supplies must be through an airlock or pass-through system. On entering, personnel must put on a complete change of clothing; before leaving, they should shower before putting on their street clothing.
3. Controlled air system. Negative pressure must be maintained in the facility. Both supply and exhaust air must be HEPA-filtered. There are significant differences in the ventilating systems of the Class III cabinet laboratory and suit laboratory:
  - Class III cabinet laboratory. The supply air to the Class III biological safety cabinet(s) may be drawn from within the room through a HEPA filter mounted on the cabinet or supplied directly through the supply air system. Exhaust air from the Class III biological safety cabinet must pass through two HEPA filters prior to release outdoors. The cabinet must be operated at negative

pressure to the surrounding laboratory at all times. A dedicated non-recirculating ventilating system for the cabinet laboratory is required.

Suit laboratory. Dedicated room air supply and exhaust systems are required. The supply and exhaust components of the ventilating system are balanced to provide directional air flow within the suit area from the area of least hazard to the area(s) of greatest potential hazard. Redundant exhaust fans are required to ensure that the facility remains under negative pressure at all times. The differential pressures within the suit laboratory and between the suit laboratory and adjacent areas must be monitored. Air flow in the supply and exhaust components of the ventilating system must be monitored and an appropriate system of controls must be used to prevent pressurization of the suit laboratory. HEPA-filtered supply air must be provided to the suit area, decontamination shower and decontamination airlocks or chambers. Exhaust air from the suit laboratory must be passed through a series of two HEPA filters prior to release outdoors. Alternatively, after double HEPA filtration, exhaust air may be recirculated but only within the suit laboratory. Under no circumstances shall the exhaust air from the Biosafety Level 4 suit laboratory be recirculated to other areas. Extreme caution must be exercised if recirculation of air within the suit laboratory is elected. Consideration must be given to the types of research conducted, equipment, chemicals and other materials used in the suit laboratory, as well as animal species that may be involved in the research.

All HEPA filters need to be tested and certified annually. The HEPA filter housings are designed to allow for *in situ* decontamination of the filter prior to removal. Alternatively, the filter can be removed in a sealed, gas-tight primary container for subsequent decontamination and/or destruction by incineration.

4. Decontamination of effluents. All effluents from the suit area, decontamination chamber, decontamination shower, or Class III biological safety cabinet must be decontaminated before final discharge. Heat treatment (autoclaving) is the preferred method. Effluents may also require correction to a neutral pH prior to discharge. Water from the personnel shower and toilet may be discharged directly to the sanitary sewer without treatment.
5. Sterilization of waste and materials. A double-door, pass-through autoclave must be available in the laboratory area. Other methods of decontamination must be available for equipment and items that cannot withstand steam sterilization.
6. Airlock entry ports for specimens, materials and animals must be provided.

### **Laboratory biosafety manual**

Because of the great complexity of the work in the Biosafety Level 4 laboratory, a separate detailed work manual should be developed and tested in training exercises. In addition, an emergency programme must be devised (see Chapter 13). In the preparation of this programme, active cooperation with national and local health authorities should be established. Other emergency services, e.g. fire, police and receiving hospitals, should also be involved.

## 6. Laboratory animal facilities

Those who use animals for experimental and diagnostic purposes have a moral obligation to take every care to avoid causing them unnecessary pain or suffering. The animals must be provided with comfortable, hygienic housing and adequate wholesome food and water. At the end of the experiment they must be dealt with in a humane manner.

For security reasons, the animal house should be an independent, detached unit. If it adjoins a laboratory, the design should provide for its isolation from the public parts of the laboratory should such need arise, and for its decontamination and disinfestation.

**Table 4. Animal facility containment levels: summary of practices and safety equipment**

| Risk Group | Containment level | Laboratory practices and safety equipment   |
|------------|-------------------|---|
| 1          | ABSL-1            | Limited access, protective clothing and gloves.   |
| 2          | ABSL-2            | ABSL-1 practices plus: hazard warning signs. Class I or II BSCs for activities that produce aerosols. Decontamination of waste and cages before washing.                                      |
| 3          | ABSL-3            | ABSL-2 practices plus: Controlled access. BSCs and special protective clothing for all activities.  |
| 4          | ABSL-4            | ABSL-3 plus: Strictly limited access. Clothing change before entering. Class III BSCs or positive pressure suits. Shower on exit. Decontamination of all wastes before removal from facility. |

ABSL, animal Biosafety Level; BSC, biological safety cabinet

Animal facilities, like laboratories, may be designated primarily according to the risk group of the microorganisms under investigation as Biosafety Level 1, 2, 3 or 4. Other factors should also be taken into consideration. With respect to the agents, these include the normal route of transmission, the volumes and concentrations to be used, the route of inoculation, and whether and by what route they may be excreted. With respect to the animals, they include the nature of the animals, i.e. their aggressiveness and tendency to bite and scratch, their natural ecto- and endoparasites, the zoonotic diseases to which they are susceptible, and the possible dissemination of allergens.

As with laboratories, the requirements for design features, equipment and precautions increase in stringency according to the biosafety level. These are described below and summarized in Table 4. These guidelines are additive, so that each higher level incorporates the standards of the lower levels.

### Animal facility – Biosafety Level 1

This is suitable for the maintenance of most stock animals after quarantine (except nonhuman primates, regarding which national authorities should be consulted) and for animals that are deliberately inoculated with agents in Risk Group 1. Good microbiological technique is required. The animal facility director must establish policies, procedures and protocols for all operations and for access to the vivarium. An appropriate medical surveillance programme for the staff must be instituted. A safety or operations manual must be prepared and adopted.



## Animal facility – Biosafety Level 2

This is suitable for work with animals that are deliberately inoculated with microorganisms in Risk Group 2. The following safety precautions apply.

1. All the requirements for animal facilities – Biosafety Level 1 must be met.
2. Biohazard warning signs (see Fig. 1) should be posted on doors and other appropriate places, and should identify the infectious agent(s) in use.
3. The facility must be designed for easy cleaning and housekeeping.
4. Doors must open inwards and be self-closing.
5. Heating, ventilation and lighting must be adequate.
6. If mechanical ventilation is provided, the air flow must be inwards. Exhaust air is discharged to the outside and should not be recirculated to any part of the building.
7. Access must be restricted to authorized persons.
8. No animals should be admitted other than those for experimental use.
9. There should be an arthropod and rodent control programme.
10. Windows, if present, must be secure, resistant to breakage and, if able to be opened, must be fitted with arthropod-proof screens.
11. After use, work surfaces must be decontaminated with effective disinfectants (see Chapter 14).
12. Biological safety cabinets (Classes I or II) or isolator cages with dedicated air supplies and HEPA-filtered exhaust air must be provided for work that may involve the generation of aerosols.
13. An autoclave must be available on site or nearby.
14. Animal bedding materials must be removed in a manner that minimizes the generation of aerosols and dust.
15. All waste materials and bedding must be decontaminated before disposal.
16. Use of sharp instruments should be restricted whenever possible. Sharps should always be collected in puncture-proof containers fitted with covers and treated as infectious.
17. Material for autoclaving or incineration must be transported safely in closed containers.
18. Animal cages must be decontaminated after use.
19. Animal carcasses must be incinerated.
20. Protective clothing and equipment must be worn in the facility, and removed on leaving. Suitable gloves should be available and be worn.
21. Hand-washing facilities must be provided. Staff must wash their hands before leaving the animal facility.
22. All injuries, however minor, must be reported and recorded.
23. Eating, drinking and application of cosmetics must be forbidden in the facility.
24. All personnel must receive appropriate training.

## Animal facility – Biosafety Level 3

This is suitable for work with animals that are deliberately inoculated with agents in Risk Group 3. All systems, practices and procedures need to be reviewed and recertified annually.

1. All the requirements for animal facilities – Biosafety Levels 1 and 2 must be met.
2. Access must be strictly controlled.
3. The facility must be separated from other laboratory and animal house areas by a room with two doors, forming an anteroom.
4. Hand-washing facilities and showers must be provided in the anteroom.
5. There must be mechanical ventilation to ensure a continuous air flow through all the rooms. Exhaust air must pass through HEPA filters before being discharged to the atmosphere without recirculation. The system must be designed to prevent accidental reverse flow and positive pressurization in any part of the animal house.
6. An autoclave must be available at a location convenient for the animal house where the biohazard is contained. Infectious waste should be autoclaved before it is moved to other areas of the facility.
7. An incinerator should be readily available on site or alternative arrangements should be made with the authorities concerned.
8. Animals infected with Risk Group 3 microorganisms must be housed in cages in isolators or rooms with ventilation exhausts placed behind the cages.
9. Bedding should be as dust-free as possible.

10. Laboratory protective clothing must be worn in the facility. This protective clothing must not be worn outside the laboratory and it must be decontaminated before it is laundered.
11. Windows must be closed and sealed, and resistant to breakage.
12. Immunization of staff, as appropriate, should be offered.

## **Animal facility – Biosafety Level 4**

Work in this facility will normally be linked with that in the maximum containment laboratory – Biosafety Level 4, and national and local rules and regulations must be harmonized to apply to both. If work is to be done in a suit laboratory, additional practices and procedures must be used other than those described here (see Chapter 5).

1. All the requirements for animal facilities – Biosafety Levels 1, 2 and 3 must be met.
2. Access must be strictly controlled; only staff designated by the director of the establishment should have authority to enter.
3. Individuals must not work alone: the two-person rule must apply.
4. Personnel must have received the highest possible level of training as microbiologists and be familiar with the hazards involved in their work and the necessary precautions.
5. Housing areas for animals infected with Risk Group 4 agents must maintain the criteria for containment described and applied for maximum containment – Biosafety Level 4 laboratories.
6. The facility must be entered by an airlock anteroom, the clean side of which must be separated from the restricted side by changing and showering facilities.
7. The facility must be ventilated by a HEPA-filtered exhaust system designed to ensure a negative pressure (inward directional air flow).
8. The ventilation system must be designed to prevent reverse flow and positive-pressurization.
9. A double-ended autoclave must be provided for delivery of materials, with the clean end in a room outside the containment rooms.
10. Staff must remove street clothing when entering and put on special, protective clothing. After work they must remove the protective clothing for autoclaving, and shower before leaving.
11. A pass-through airlock must be provided for delivery of materials.
12. All manipulations with animals infected with Risk Group 4 agents must take place under maximum containment – Biosafety Level 4 conditions.
13. All animals must be housed in isolators.
14. All bedding and waste must be autoclaved before removal from the facility.
15. There must be medical supervision of staff and immunization as appropriate.

## **Invertebrates**

The invertebrates that are used for experimental purposes in laboratories are usually the reservoirs or vectors of pathogens or, as in the case of ecological and environmental investigations, may be fortuitously infected with pathogens ingested with their food. They may include members of the following phyla: Annelida, Aschelminthes, Arthropoda, Echinodermata, Mollusca, Platyhelminthes and Protozoa.

As with vertebrates, the animal facility biosafety level will be determined by the risk groups of the agents under investigation or naturally present, but the following additional precautions are necessary with certain arthropods, particularly with flying insects.

1. Separate rooms should be provided for infected and noninfected invertebrates.
2. The rooms should be capable of being sealed for fumigation.
3. Insecticide sprays should be readily available.
4. "Chilling" facilities should be provided to reduce, where necessary, the activity of invertebrates.
5. Access should be through an anteroom containing insect traps and with arthropod-proof screens on the doors.
6. All exhaust ventilation ducts and openable windows should be fitted with arthropod-proof screens.
7. Waste traps on sinks and sluices should not be allowed to dry out.
8. All waste should be decontaminated by autoclaving, as some invertebrates are not killed by all disinfectants.
9. A check should be kept on the numbers of larval and adult forms of flying, crawling and jumping arthropods.

10. Containers for ticks and mites should stand in trays of oil.
11. Infected or potentially infected flying insects must be contained in double-netted cages.
12. Infected or potentially infected arthropods must be handled in biological safety cabinets or isolators.
13. Infected or potentially infected arthropods may be manipulated on cooling trays.

For further information see references 1 and 6-9.

interim guidelines

interim guidelines

## **PART II**

### Laboratory equipment

interim guidelines

interim guidelines

## 7. Biological safety cabinets

Biological safety cabinets (BSCs) are designed to protect the operator, the laboratory environment and work materials from exposure to infectious aerosols and splashes that may be generated when manipulating materials containing infectious agents, such as primary cultures, stocks and diagnostic specimens. Aerosol particles are created by any activity that imparts energy into a liquid or semiliquid material, such as shaking, pouring, stirring or dropping liquid on to a surface or into another liquid. Laboratory activities, such as streaking agar plates, inoculating cell culture flasks with a pipette, using a multichannel pipette to dispense liquid suspensions of infectious agents into microculture plates, homogenizing and vortexing infectious materials, and centrifugation of infectious liquids, or working with animals, can generate infectious aerosols. Aerosol particles of less than 5 µm in diameter and small droplets of 5–100 µm in diameter are not visible to the naked eye. The laboratory worker is generally not aware that such particles are being generated and may be inhaled or may cross-contaminate work surface materials. BSCs, when properly used, have been shown to be highly effective in reducing laboratory-acquired infections and cross-contaminations of cultures due to aerosol exposures. Each BSC also protects the environment.

**Table 5. Selection of a biological safety cabinet (BSC), by type of protection needed**

| Type of protection   | BSC selection                                     |
|--|---|
| Personnel protection, microorganisms in Risk Groups 1–3                    | Class I, Class II, Class III                      |
| Personnel protection, microorganisms in Risk Group 4, glove box laboratory | Class III   |
| Personnel protection, microorganisms in Risk Group 4, suit laboratory      | Class I, Class II                                 |
| Product protection   | Class II, Class III only if laminar flow included |
| Volatile radionuclide/chemical protection, minute amounts                  | Class IIB1, Class IIA2 vented to the outside      |
| Volatile radionuclide/chemical protection                                  | Class I, Class IIB2, Class III                    |

Over the years the basic design of BSCs has undergone several design modifications. A major change was the addition of a high-efficiency particulate air (HEPA) filter to the exhaust system. The HEPA filter traps 99.97% of particles of 0.3 µm in diameter and 99.99% of particles of greater or smaller size. This enables the HEPA filter to effectively trap all known infectious agents and ensure that only microbe-free exhaust air is discharged from the cabinet. A second design modification was to direct HEPA-filtered air over the work surface, providing protection of work surface materials from contamination. This feature is often referred to as product protection. These basic design concepts have led to the evolution of three classes of BSCs. The type of protection provided by each is set out in Table 5.

**Note.** Horizontal and vertical outflow cabinets (“clean-air work stations”) are **not** biological safety cabinets and should not be used as such.

## Class I biological safety cabinet

Fig. 3 provides a schematic diagram of a Class I BSC. Room air is drawn in through the front opening at a minimum velocity of 0.38 m/s, it passes over the work surface and is discharged from the cabinet through the exhaust duct. The directional flow of air whisks aerosol particles that may be generated on the work surface away from the laboratory worker and into the exhaust duct. The front opening allows the operator's arms to reach the work surface inside the cabinet while he or she observes the work surface through a glass window. The window can also be fully raised to provide access to the work surface for cleaning or other purposes.

The air from the cabinet is exhausted through a HEPA filter: (a) into the laboratory and then to the outside of the building through the building exhaust; (b) to the outside through the building exhaust; or (c) directly to the outside. The HEPA filter may be located in the exhaust plenum of the BSC or in the building exhaust. Some Class I BSCs are equipped with an integral exhaust fan, whereas others rely on the exhaust fan in the building exhaust system.

The Class I BSC was the first recognized BSC and, because of its simple design, it is still in wide use throughout the world. It has the advantage of providing personnel and environmental protection and can also be used for work with radionuclides and volatile toxic chemicals. Because unsterilized room air is drawn over the work surface through the front opening, it is not considered to provide consistently reliable product protection.

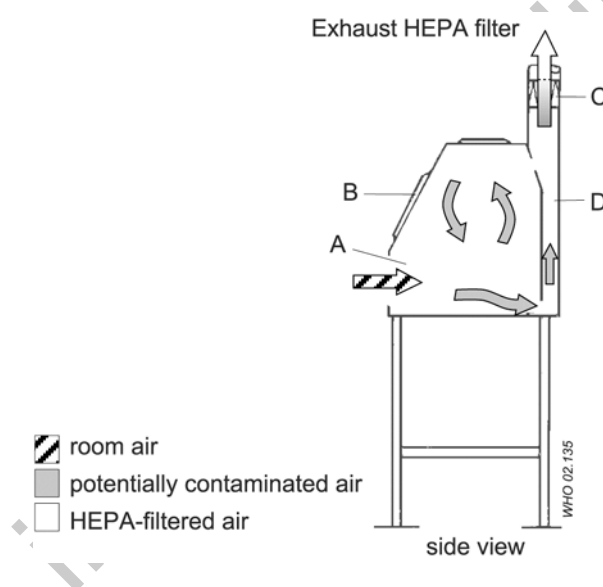

**Fig. 3. Schematic diagram of a Class I biological safety cabinet.** A: front opening, B: sash, C: exhaust HEPA filter, D: exhaust plenum.

## Class II biological safety cabinets

As the use of cell and tissue cultures for the propagation of viruses and other purposes grew, it was no longer considered satisfactory for unsterilized room air to pass over the work surface. The Class II BSC was designed not only to provide personnel protection but also to protect work surface materials from contaminated room air. Class II BSCs, of which there are four types (A1, A2, B1 and B2), differ from Class I BSCs by allowing only HEPA-filtered (sterile) supply air to flow over the work surface. The Class II BSC can be used for working with infectious agents in Risk Groups 2 and 3. Class II BSCs can be used for working with infectious agents in Risk Group 4 when positive pressure suits are used.

### Class II type A1 biological safety cabinet

The Class II type A BSC is shown in Fig. 4. An internal fan draws room air (supply air) into the cabinet through the front opening and into the front intake grill. The inflow velocity of this air should be at least 0.38 m/s at the face of the front opening. The supply air then passes through a supply HEPA filter before



flowing downwards over the work surface. As the air flows downwards it “splits” about 6–18 cm from the work surface, one half of the downwards flowing air passing through the front exhaust grill, and the other half passing through the rear exhaust grill. Any aerosol particles generated at the work surface are immediately captured in this downward air flow and passed through the front or rear exhaust grills, thereby providing the highest level of product protection. The air is then discharged through the rear plenum into the space between the supply and exhaust filters located at the top of the cabinet. Owing to the relative size of these filters, about 70% of the air recirculates through the supply HEPA filter back into the work zone; the remaining 30% passes through the exhaust filter into the room or to the outside.

Air from the Class IIA1 BSC exhaust can be recirculated to the room or discharged to the outside of the building through a thimble connection to a dedicated duct or through the building exhaust system.

Recirculating the exhaust air to the room has the advantage of lowering building fuel costs because heated and/or cooled air is not being passed to the outside environment. A connection to a ducted exhaust system also allows some BSCs to be used for work with volatile radionuclides and volatile toxic chemicals (Table 5).

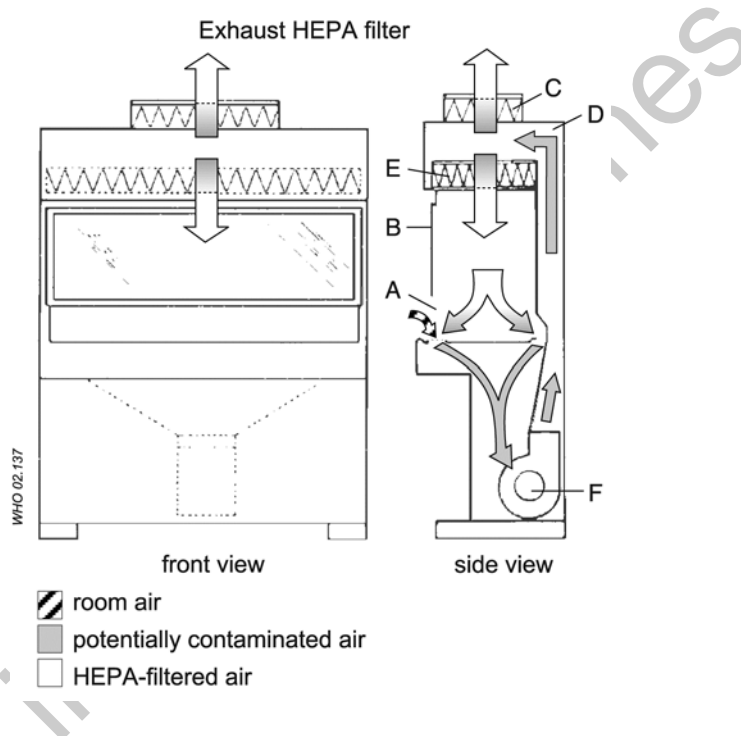
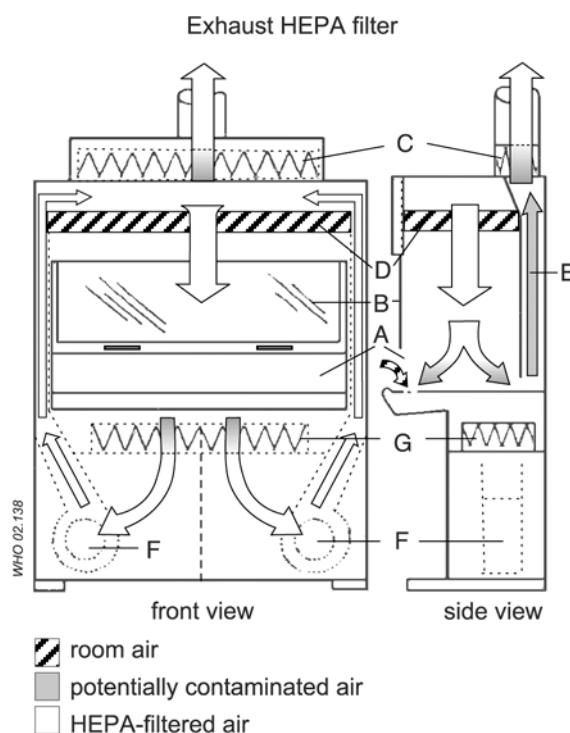

**Fig. 4. Schematic representation of a Class IIA1 biological safety cabinet.** A: front opening, B: sash, C: exhaust HEPA filter, D: rear plenum, E: supply HEPA filter, F: blower.

### ***Class II type A2 vented to the outside, B1 and B2 biological safety cabinets***

Class IIA2 vented to the outside, IIB1 (Fig. 5) and IIB2 BSCs are variations of the type IIA1, and their characteristics, along with those of Class I and Class III BSCs, are indicated in Table 6. Each variation allows the BSC to be used for specialized purposes (see Table 5). These BSCs differ from one another in several aspects: the air intake velocity through the front opening; the amount of air recirculated over the work surface and exhausted from the cabinet; the exhaust system, which determines whether air from the cabinet is exhausted to the room, or to the outside, through a dedicated exhaust system or through the building exhaust; and the pressure arrangements (whether cabinets have biologically contaminated ducts and plenums under negative pressure, or have biological contaminated ducts and plenums surrounded by negative-pressure ducts and plenums).

Complete descriptions of the various Class IIA and IIB BSCs can be obtained from references 10 and 11, and from manufacturers' brochures.



**Fig. 5. Schematic diagram of a Class IIB1 biological safety cabinet.** A: front opening, B: sash, C: exhaust HEPA filter, D: supply HEPA filter, E: negative pressure exhaust plenum, F: blower, G: HEPA filter for supply air. Connection of cabinet exhaust to building exhaust air system is required.

**Table 6. Differences between Class I, II and III biological safety cabinets (BSCs)**

| BSC  | Face velocity<br>(m/s) | % of air flow |           | Exhaust system                        |
|--|------------------------|---------------|-----------|---------------------------------------|
|  |                        | Recirculated  | Exhausted |                                       |
| Class I <sup>a</sup>   | 0.36                   | 0             | 100       | Hard duct                             |
| Class IIA1   | 0.38–0.51              | 70            | 30        | Exhaust to room or thimble connection |
| Class IIA2 <sup>a</sup><br>vented to the<br>outside <sup>a</sup> | 0.51                   | 70            | 30        | Exhaust to room or thimble connection |
| Class IIB1 <sup>a</sup>  | 0.51                   | 30            | 70        | Hard duct                             |
| Class IIB2 <sup>a</sup>  | 0.51                   | 0             | 100       | Hard duct                             |
| Class III <sup>a</sup>   | NA <sup>b</sup>        | 0             | 100       | Hard duct                             |

<sup>a</sup> All biologically contaminated ducts are under negative pressure, or are surrounded by negative pressure ducts and plenums.

<sup>b</sup> NA, not applicable.

### Class III biological safety cabinet

This type (Fig. 6) provides the highest level of personnel protection and is used for Risk Group 4 agents. All penetrations are sealed “gas tight”. Supply air is HEPA-filtered and exhaust air passes through two HEPA filters. Air flow is maintained by a dedicated exhaust system exterior to the cabinet, which keeps the cabinet interior under negative pressure (about 124.5 Pa). Access to the work surface is by means of heavy duty rubber gloves, which are attached to ports in the cabinet. The Class III BSC should have an attached pass-through box that is sterilizable and is equipped with HEPA-filtered exhaust. The Class III

cabinet may be connected to a double-door autoclave used to decontaminate all materials entering or exiting the cabinet. Several glove boxes can be joined together to extend the work surface. Class III BSCs are suitable for work in Biosafety Level 3 and 4 laboratories.

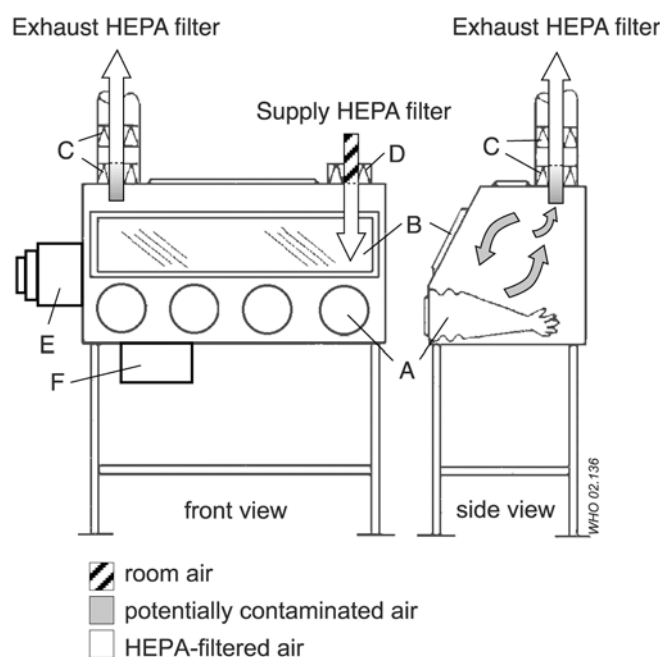

**Fig. 6. Schematic representation of a Class III biological safety cabinet (glove box).** A: glove ports for arm-length gloves, B: sash, C: double exhaust HEPA filters, D: supply HEPA filter, E: double-ended autoclave or pass-through box, F: chemical dunk tank. Connection of cabinet exhaust to an independent building exhaust air system is required.

## Biological safety cabinet air connections

A “thimble” or “canopy hood” is designed for use with Class IIA1 and IIA2 vented to the outside BSCs. The thimble fits over the cabinet exhaust housing, sucking the cabinet exhaust air into the building exhaust ducts. A small opening, usually 2.5 cm in diameter, is maintained between the thimble and the cabinet exhaust housing. This small opening enables room air to be sucked into the building exhaust system as well. The building exhaust capacity must be sufficient to capture both room air and the cabinet exhaust. The thimble must be removable or be designed to allow for operational testing of the cabinet. Generally, the performance of a thimble-connected BSC is not affected much by fluctuations in the air flow of the building

Class IIB1 and IIB2 BSCs are hard-ducted, i.e. firmly connected without any openings, to the building exhaust system or, preferably, to a dedicated exhaust duct system. The building exhaust system must precisely match to the air flow requirements specified by the manufacturer in both volume and static pressure. Certification of hard-duct connected BSCs is more time-consuming than that for BSCs that recirculate air to the room or which are thimble-connected.

## Selection of a biological safety cabinet

A BSC should be selected primarily in accordance with the type of protection needed: product protection; personnel protection against Risk Group 1–4 microorganisms; personnel protection against exposure to radionuclides and volatile toxic chemicals; or a combination of these. Table 5 shows which BSCs are recommended for each type of protection.

Volatile or toxic chemicals should not be used in BSCs that recirculate exhaust air to the room, i.e. Class I that are not ducted to building exhaust systems, or Class IIA1 or Class IIA2 cabinets. Class IIB1

cabinets are acceptable for work with minute amounts of volatile chemicals and radionuclids. A Class IIB2 cabinet, also called a total exhaust cabinet, is necessary when significant amounts of radionuclides and volatile chemicals are expected to be used.

## Using biological safety cabinets in the laboratory

### **Location**

The velocity of air flowing through the front opening into a BSC is about 0.45 m/s. At this velocity the integrity of the directional air inflow is fragile and can be easily disrupted by air currents generated by people walking close to the BSC, open windows, air supply registers, and opening and shutting doors. Ideally, BSCs should be situated in a location remote from traffic and potentially disturbing air currents. Whenever possible a 30-cm clearance should be provided behind and on each side of the cabinet to allow easy access for maintenance. A clearance of 30–35 cm above the cabinet may be required to provide for accurate air velocity measurement across the exhaust filter and for exhaust filter changes.

### **Operators**

If BSCs are not used properly, their protective benefits may be greatly diminished. Operators need to be careful to maintain the integrity of the front opening air inflow when moving their arms into and out of cabinets. Arms should be moved in and out slowly, perpendicular to the front opening. Manipulations of materials within BSCs should be delayed for about 1 min after placing hands and arms inside to allow the cabinet to adjust and to “air sweep” the surface of the hands and arms. The number of movements across the front opening should also be minimized by placing all necessary items into the cabinet before beginning manipulations.

### **Material placement**

The front intake grill of Class II BSCs must not be blocked with paper, equipment or other items. Materials to be placed inside the cabinet should be surface-decontaminated with 70% alcohol. Work may be performed on disinfectant-soaked absorbent towels to capture splatters and splashes. All materials should be placed as far back in the cabinet, towards the rear edge of the work surface, as practical without blocking the rear grill. Aerosol-generating equipment (e.g. mixers, centrifuges, etc.) should be placed towards the rear of the cabinet. Bulky items, such as biohazard bags, discard pipette trays and suction collection flasks should be placed to one side of the interior of the cabinet. Active work should flow from clean to contaminated areas across the work surface.

The autoclavable biohazard collection bag and pipette collection tray should not be placed outside the cabinet. The frequent in-and-out movement needed to use these containers is disruptive to the integrity of the cabinet's air barrier, and can compromise both personnel and product protection.

### **Operation and maintenance**

Most BSCs are designed to permit operation 24 h/day, and investigators find that continuous operation helps to control the levels of dust and particulate materials in the laboratory. Class IIA1 and IIA2 BSCs exhausting to the room or connected by thimble connections to dedicated exhaust ducts can be turned off when not in use. Other types such as IIB1 and IIB2 BSCs, which have hard-duct installations, must have air flow through them at all times to help maintain room air balance. Cabinets should be turned on at least 5 min before beginning work and after completion of work to allow the cabinet to “purge”, i.e. to allow time for contaminated air to be removed from the cabinet environment.

All repairs made on BSCs should be made by a qualified technician. Any malfunction in the operation of the BSC should be reported and repaired before the BSC is used again.

### **Ultraviolet lights**

Ultraviolet lights are not required in BSCs. If they are used, they must be cleaned weekly to remove any dust and dirt that may block the germicidal effectiveness of the light. Ultraviolet light intensity should be checked when the cabinet is recertified to ensure that light emission is appropriate. Ultraviolet lights must be turned off while the room is occupied, to protect eyes and skin from inadvertent exposure.

### **Open flames**

Open flames should be avoided in the near microbe-free environment created inside the BSC. They disrupt the air flow patterns and can be dangerous when volatile, flammable substances are also used. To sterilize bacteriological loops, microburners or electric "furnaces" are available and are preferable to open flames.

### **Spills**

A copy of the laboratory's protocol for handling spills should be posted, read and understood by everyone who uses the laboratory. When a spill of biohazardous material occurs within a BSC, cleanup should begin immediately, while the cabinet continues to operate. An effective disinfectant should be used and applied in a manner that minimizes the generation of aerosols. All materials that come into contact with the spilled agent should be disinfected and/or autoclaved.

### **Annual certification**

The functional operation and integrity of each BSC should be certified to national or international performance standards at the time of installation and regularly thereafter by qualified technicians, according to the manufacturer's instructions. Evaluation of the effectiveness of cabinet containment should include tests for cabinet integrity, HEPA filter leaks, downflow velocity profile, face velocity, negative pressure/ventilation rate, air flow smoke pattern, and alarms and interlocks. Optional tests for electrical leaks, lighting intensity, ultraviolet light intensity, noise level and vibration may also be conducted. Special training, skills and equipment are required to perform these tests and it is highly recommended that they are undertaken by a qualified professional.

### **Cleaning and disinfection**

All items within BSCs, including equipment, should be surface-decontaminated and removed from the cabinet when work is completed, since residual culture media may provide an opportunity for microbial growth.

The interior surfaces of BSCs should be decontaminated before and after each use. The work surfaces and interior walls should be wiped with a disinfectant that will kill any microorganisms that might be found inside the cabinet. At the end of the work day, the final surface decontamination should include a wipe-down of the work surface, the sides, back and interior of the glass. A solution of bleach or 70% alcohol should be used where effective for target organisms. A second wiping with sterile water is needed when a corrosive disinfectant, such as bleach, is used.

It is recommended that the cabinet be left running. If not, it should be run for 5 min in order to purge the atmosphere inside before it is switched off.

### **Decontamination**

BSCs must be decontaminated before filter changes and before being moved. The most common decontamination method is by fumigation with formaldehyde gas. BSC decontamination should be performed by a qualified professional.

### **Personal protective equipment**

Personal protective clothing should be worn whenever using a BSC. Laboratory coats are acceptable for work being performed at Biosafety Levels 1 and 2. A solid front, back-closing laboratory gown provides better protection and should be used at Biosafety Levels 3 and 4 (except for suit laboratories). Gloves should be pulled over the wrists of the gown rather than worn inside. Elasticized sleeves can be worn to protect the investigator's wrists. Masks and safety glasses may be required for some procedures.

### **Alarms**

BSCs can be equipped with one of two kinds of alarm. Sash alarms are found only on cabinets with sliding sashes. The alarm signifies that the operator has moved the sash to an improper position. Corrective action for this type of alarm is returning the sash to the proper position. Air-flow alarms

indicate a disruption in the cabinet's normal air-flow pattern. This represents an immediate danger to the operator or product. When an air-flow alarm sounds, work should cease immediately and the laboratory supervisor should be notified. Manufacturers' instruction manuals should provide further details. Training in the use of BSCs should cover this aspect.

### ***Supplementary information***

Selecting the correct type of BSC, installing it, using it properly and annually certifying its operation are complex processes. It is highly recommended that they proceed under the supervision of a well-trained and experienced biosafety professional. The professional should be highly familiar with the relevant literature listed in the References section, and should have been trained on all aspects of BSCs. Operators should receive formal training in the operation and use of BSCs.

For further information see references 1 and 10-19, and Chapter 10.

interim guidelines

## 8. Equipment-related hazards

Certain items of equipment may create microbiological hazards when they are used. Other items are specifically designed to prevent or reduce biological hazards (see Chapter 9).

### Equipment that may create a hazard

Table 7 lists equipment and operations that may create hazards and suggests how such hazards may be eliminated or reduced.

**Table 7. Equipment and operations that may create hazards**

| Equipment          | Hazard   | How to eliminate or reduce the hazard  |
|--------------------|--|--|
| Hypodermic needles | Accidental inoculation, aerosol or spillage (20) | <ul style="list-style-type: none"> <li>÷ Do not recap or clip needles.</li> <li>÷ Use a needle-locking type of syringe to prevent separation of needle and syringe, or use a disposable type where the needle is an integral part of the syringe unit.</li> <li>÷ Use good laboratory techniques, e.g.:               <ul style="list-style-type: none"> <li>– fill the syringe carefully to minimize air bubbles and frothing of inoculum</li> <li>– avoid using syringes to mix infectious liquids; if used, ensure that the tip of the needle is held under the surface of the fluid in the vessel and avoid excessive force</li> <li>– wrap the needle and stopper in a cotton pledget moistened with an appropriate disinfectant before withdrawing the needle from a rubber-stoppered bottle</li> <li>– expel excess liquid and air bubbles from the syringe vertically into a cotton pledget moistened with an appropriate disinfectant or into a small bottle containing cotton.</li> </ul> </li> <li>÷ Use a biological safety cabinet for all operations with infectious material.</li> <li>÷ Restrain animals while they are being inoculated. Use blunt needles or cannulas for intranasal or oral inoculation. Use a biological safety cabinet.</li> <li>÷ Autoclave after use and ensure proper disposal. If a disposable needle and syringe unit is used, do not disassemble prior to autoclaving.</li> </ul> |
| Centrifuges        | Aerosols, splashing and tube breakage            | <ul style="list-style-type: none"> <li>÷ Use sealable buckets (safety cups) or sealed rotors. Open buckets or rotors after aerosols have settled (30 min) or in a biological safety cabinet.</li> </ul>  |
| Ultra-             | Aerosols, splashing and                          | <ul style="list-style-type: none"> <li>÷ Install a HEPA filter between centrifuge and vacuum</li> </ul>  |

| Equipment                            | Hazard   | How to eliminate or reduce the hazard   |
|--------------------------------------|--|---|
| centrifuges                          | tube breakage  | <p>pump.</p> <ul style="list-style-type: none"> <li>÷ Maintain a logbook of operating hours for each rotor and a preventive maintenance programme to reduce risk of mechanical failure.</li> <li>÷ Load and unload buckets or rotors in a biological safety cabinet.</li> </ul>   |
| Anaerobic jars                       | Explosion, dispersing infectious materials   | <ul style="list-style-type: none"> <li>÷ Ensure integrity of wire capsule around catalyst.</li> </ul>   |
| Desiccators                          | Implosion, dispersing glass fragments and infectious materials                     | <ul style="list-style-type: none"> <li>÷ Place in a stout wire cage.</li> </ul>   |
| Homogenizer, tissue grinders         | Aerosols, leakage and container breakage   | <ul style="list-style-type: none"> <li>÷ Operate and open equipment in a biological safety cabinet.</li> <li>÷ Use specially designed models that prevent leakage from rotor bearings and O-ring gaskets, or use a stomacher.</li> <li>÷ Before opening the blender bowl, wait 30 min to allow the aerosol cloud to settle. Refrigerate to condense aerosols.</li> <li>÷ If manual tissue grinders are used, hold tube in a wad of absorbent material.</li> </ul> |
| Sonicators, ultrasonic cleaners      | Aerosols, impaired hearing, dermatitis   | <ul style="list-style-type: none"> <li>÷ Operate and open equipment in a biological safety cabinet or sealed unit.</li> <li>÷ Ensure insulation to protect against subharmonics.</li> <li>÷ Wear gloves for protection against high-frequency plus detergent action on skin.</li> </ul>   |
| Culture stirrers, shakers, agitators | Aerosols, splashing and spillage   | <ul style="list-style-type: none"> <li>÷ Operate in a biological safety cabinet or specially designed primary containment.</li> <li>÷ Use heavy-duty screw-capped culture flasks, fitted with filter-protected outlets, if necessary, and well secured.</li> </ul>  |
| Freeze-dryers (lyophilizers)         | Aerosols and direct contact contamination  | <ul style="list-style-type: none"> <li>÷ Use O-ring connectors to seal the unit throughout.</li> <li>÷ Use air filters to protect vacuum lines.</li> <li>÷ Use a satisfactory method of decontamination, e.g. chemical.</li> <li>÷ Provide an all-metal moisture trap and a vapour condenser.</li> <li>÷ Carefully inspect all glass vacuum vessels for surface scratches. Use only glassware designed for vacuum work.</li> </ul>                                |
| Water baths and Warburg baths        | Growth of microorganisms. Sodium azide forms explosive compounds with some metals. | <ul style="list-style-type: none"> <li>÷ Ensure regular cleaning and disinfection.</li> <li>÷ Do not use sodium azide for preventing growth of organisms.</li> </ul>  |



## 9. Equipment designed to reduce biological hazards

As aerosols are important sources of infection, care should be taken to reduce the extent of their formation and dispersion. Hazardous aerosols can be generated by many laboratory operations, e.g. blending, mixing, grinding, shaking, stirring, sonicating and centrifuging of infectious materials. Even when safe equipment is used, it is best to carry out these operations in an approved biological safety cabinet whenever possible. Biological safety cabinets and their use and testing are discussed in Chapter 7. The use of safety equipment is no assurance of protection unless the operator is trained and uses proper techniques. Equipment should be tested regularly to ensure its continued safe performance.

Table 8 provides a checklist of safety equipment designed to eliminate or reduce certain hazards and briefly outlines the safety features. Further details of much of this equipment are given in subsequent pages. Additional information on its proper use is provided in Chapter 10.

**Table 8. Biosafety equipment**

| Equipment   | Hazard corrected   | Safety features   |
|---|--|---|
| Biological safety cabinet   |  |   |
| – Class I   | Aerosol and spatter  | ÷ Minimum inward air flow (face velocity) at work access opening.<br>÷ Adequate filtration of exhaust air   |
| – Class II  | Aerosol and spatter  | ÷ Minimum inward air flow (face velocity) at work access opening.<br>÷ Adequate filtration of exhaust air   |
| – Class III   | Aerosol and spatter  | ÷ Maximum containment   |
| Negative pressure flexible-film isolator  | Aerosol and spatter  | ÷ Maximum containment   |
| Spatter shield  | Spatter of chemicals   | ÷ Forms screen between operator and work  |
| Pipetting aids  | Hazards from pipetting by mouth, e.g. ingestion of pathogens, inhalation of aerosols produced by mouth suction on pipette, blowing out of liquid or dripping from pipette, contamination of suction end of pipette | ÷ Ease of use<br>÷ Control contamination of suction end of pipette, protecting pipetting aid, user and vacuum line<br>÷ Can be sterilized<br>÷ Control leakage from pipette tip |
| Loop microincinerators, disposable loops  | Spatter from transfer loops  | ÷ Shielded in open-ended glass or ceramic tube, heated by gas or electricity<br>÷ Disposable, no heating necessary  |
| Leakproof vessels for collection and transport of infectious materials for sterilization within a | Aerosols, spillage and leakage   | ÷ Leakproof construction with lid or cover<br>÷ Durable<br>÷ Autoclavable   |

| Equipment   | Hazard corrected  | Safety features  |
|---|---|--|
| facility  |   |  |
| Sharps disposal containers                              | Accidental puncture wounds  | <ul style="list-style-type: none"> <li>÷ Autoclavable</li> <li>÷ Robust, puncture proof</li> </ul>   |
| Transport containers between laboratories, institutions | Accidental escape of microorganisms   | <ul style="list-style-type: none"> <li>÷ Robust</li> <li>÷ Water-tight primary and secondary containers to contain spills</li> <li>÷ Absorbent material to contain spills</li> </ul>   |
| Autoclaves, manual or automatic                         | Infectious material (made safe for disposal or reuse)                       | <ul style="list-style-type: none"> <li>÷ Approved design</li> <li>÷ Effective heat sterilization</li> </ul>  |
| Screw-capped bottles                                    | Aerosols and spillage   | <ul style="list-style-type: none"> <li>÷ Effective containment</li> </ul>  |
| Vacuum line protection                                  | Contamination of laboratory vacuum system with aerosols and overflow fluids | <ul style="list-style-type: none"> <li>÷ Cartridge-type filter prevents passage of aerosols (particle size 0.45 <math>\mu\text{m}</math>)</li> <li>÷ Overflow flask contains appropriate disinfectant. Rubber bulb may be used to close off vacuum automatically when storage flask is full</li> <li>÷ Entire unit autoclavable</li> </ul> |

## Negative-pressure flexible-film isolators

The negative-pressure flexible-film isolator is a self-contained primary containment device that provides maximum protection against hazardous biological materials. It may be mounted on a mobile stand. The workspace is totally enclosed in a transparent polyvinylchloride (PVC) envelope suspended from a steel framework. The isolator is maintained at an internal pressure lower than atmospheric pressure. Inlet air is passed through one HEPA filter and outlet air is passed through two HEPA filters, thus obviating the need to duct exhaust air outside the building. The isolator may be fitted with an incubator, microscope and other laboratory equipment, such as centrifuges, animal cages, heat blocks, etc. Material is introduced and removed from the isolator through supply and sample ports without compromising microbiological security. Manipulations are performed using gloved sleeves incorporating disposable gloves. A manometer is installed to monitor envelope pressure.

Flexible-film isolators are used for high-risk organisms (Risk Groups 3 or 4) where it is not feasible to install or maintain conventional biological safety cabinets. They may be transported for use in field work.

## Pipetting aids

A pipetting aid must always be used for pipetting procedures. Mouth pipetting must be strictly forbidden.

The importance of pipetting aids cannot be overemphasized. The most common hazards associated with pipetting procedures are the result of mouth suction. Oral aspiration and ingestion of hazardous materials have been responsible for many laboratory-associated infections and accidents.

Pathogens can also be transferred to the mouth if a contaminated finger is placed on the suction end of a pipette. A lesser known hazard of mouth pipetting is the inhalation of aerosols caused by suction. The cotton plug is not an efficient microbial filter at negative or positive pressure, and particles may be sucked through it. Violent suction may be applied when the plug is tightly packed, resulting in the aspiration of plug, aerosol and even liquid. The ingestion of pathogens is prevented by the use of pipetting aids.

Aerosols can also be generated when a liquid is dropped from a pipette on to a work surface, when cultures are mixed by alternate sucking and blowing, and when the last drop is blown out of a pipette.

The inhalation of aerosols unavoidably generated during pipetting operations can be prevented by working in a biological safety cabinet.

Pipetting aids should be selected with care. Their design and use should not create an additional infectious hazard and they should be easy to sterilize and clean. Plugged (aerosol-resistant) pipette tips should be used when manipulating microorganisms and cell cultures.

Pipettes with cracked or chipped suction ends should not be used as they damage the seating seals of pipetting aids and so create a hazard.

## Homogenizers, shakers, blenders and sonicators

Domestic (kitchen) homogenizers are not sealed and release aerosols. Only equipment designed for laboratory use should be used. Their construction minimizes or prevents such release. Stomachers, which are now available for use with large and small volumes, may also produce aerosols.

Homogenizers used for Risk Group 3 microorganisms should always be loaded and reopened in biological safety cabinets.

Sonicators may release aerosols. They should be operated in biological safety cabinets or covered with shields during use. The shields and outsides of sonicators should be decontaminated after use.

## Disposable transfer loops

The advantage of disposable transfer loops is that they do not have to be sterilized and can therefore be used in biological safety cabinets where Bunsen burners and microincinerators would disturb the air flow. These loops should be placed in disinfectant after use and discarded as contaminated waste (see section on Contaminated (infectious) materials for disposal in Chapter 3).

## Microincinerators

Gas- and electrically-heated microincinerators have borosilicate glass or ceramic shields that minimize the spatter and dispersal of infected material when transfer loops are sterilized. However, microincinerators disturb the air flow and should therefore not be used in biological safety cabinets.

## Personal protective clothing and equipment

Personal protective clothing and equipment may act as a barrier to minimize the risk of exposure to aerosols, splashes and accidental inoculation. The clothing and equipment selected is dependent on the nature of the work performed. Protective clothing should be worn when working in the laboratory. Before leaving the laboratory, protective clothing should be removed, and hands should be washed. Table 9 summarizes some personal protective equipment used in laboratories and the protection afforded.

**Table 9. Personal protective equipment**

| Equipment                          | Hazard corrected          | Safety features   |
|------------------------------------|---------------------------|---|
| Laboratory coats, gowns, coveralls | Contamination of clothing | ÷ Back opening<br>÷ Cover street clothing   |
| Plastic aprons                     | Contamination of clothing | ÷ Waterproof  |
| Footwear                           | Impact and splash         | ÷ Closed toe  |
| Goggles or safety spectacles       | Impact and splash         | ÷ Impact-resistant lenses (must be optically correct or worn over corrective eye glasses)<br>÷ Side shields |
| Face shields                       | Impact and splash         | ÷ Shield entire face<br>÷ Easily removable in case of accident  |
| Respirators                        | Inhalation of aerosols    | ÷ Designs available include hoods, full-face or   |

| Equipment | Hazard corrected             | Safety features             |
|-----------|------------------------------|-----------------------------|
| Gloves    | Accidental direct contact    | half face masks             |
|           |                              | ÷ Disposable latex or vinyl |
|           | Accidental punctures or cuts | ÷ Hand protection<br>÷ Mesh |

### **Laboratory coats, gowns, coveralls, aprons**

Laboratory coats should preferably be fully buttoned. However, long-sleeved, back-opening gowns or coveralls give better protection than laboratory coats and are preferred in microbiology laboratories and when working in the biological safety cabinet. Aprons should be worn over laboratory coats or gowns where necessary to give further protection against spillage of chemicals or biological materials such as blood or culture fluids.

### **Goggles, safety spectacles, face shields**

The choice of equipment to protect the eyes and face from splashes and impacting objects will depend on the activity performed. Prescription or plain eye glasses can be manufactured with special frames that allow lenses to be placed in frame from the front, using shatterproof material either curved or fitted with side shields (safety glasses). Goggles should be worn over normal prescription eye glasses and contact lenses, which do not provide protection against biological hazards. Face shields (visors) are made of shatterproof plastic, fit over the face and are held in place by head straps or caps.

### **Respirators**

Respiratory protection may be used when carrying out high-hazard procedures (e.g. cleaning up a spill of infectious material). The choice between mask and respirator, and type of respirator will depend on the type of hazard. Respirators are available with interchangeable filters for protection against gases, vapours, particulates and microorganisms. Note that no filter other than a HEPA filter will provide protection against microorganisms, and it is imperative that the filter be fitted in the correct type of respirator. To achieve optimal protection, respirators should be individually fitted to the operator's face and tested. Fully self-contained respirators with an integral air supply provide full protection. Advice should be sought from a suitably qualified person, e.g. an occupational hygienist, for selection of the correct respirator.

### **Gloves**

Contamination of hands may occur when laboratory procedures are performed. Hands are also vulnerable to "sharps" injuries. Disposable latex or vinyl surgical-type gloves are used widely for general laboratory work, and for handling infectious agents and blood and body fluids. Reusable gloves may also be used but attention must be given to their correct washing, removal, cleaning and disinfection.

Gloves should be removed and hands thoroughly washed after handling infectious materials, working in a biological safety cabinet and before leaving the laboratory. Used disposable gloves should be discarded with infected laboratory wastes.

Allergic reactions such as dermatitis and immediate hypersensitivity have been reported in laboratory and other workers wearing latex gloves, particularly those with powder. Alternatives such as powder-free latex or vinyl gloves should be used if problems occur.

Stainless steel mesh gloves should be worn when there is a potential exposure to sharp instruments e.g. during postmortem examinations. However, such gloves protect against slicing motion but do not protect against needle injury.

For further information see references 12, 20 and 21.

## **PART III**

### **Good microbiological technique**

*interim guidelines*

interim guidelines

## 10. Safe laboratory techniques

Human error, poor laboratory techniques and misuse of equipment cause the majority of laboratory accidents, injuries and work-related infections. This chapter provides a compendium of technical methods that are designed to avoid or minimize the most commonly reported problems of this nature.

### **Safe handling of specimens in the laboratory**

Improper collection, internal transport and receipt of specimens in the laboratory carry a risk of infection to the personnel involved.

#### ***Specimen containers***

Specimen containers may be of glass or preferably plastic. They should be robust and should not leak when the cap or stopper is correctly applied. No material should remain on the outside of the container. Containers should be correctly labelled to facilitate identification. Specimen request or specification forms should not be wrapped around the containers but placed in separate, preferably waterproof envelopes.

#### ***Transport of specimens within the facility***

To avoid accidental leakage or spillage, secondary containers, such as boxes, should be used, fitted with racks so that the specimen containers remain upright. The secondary containers may be of metal or plastic, should be autoclavable or resistant to the action of chemical disinfectants, and the seal should preferably have a gasket. They should be regularly decontaminated. Transport of specimens to the facility from distant locations is described in Chapter 12.

#### ***Receipt of specimens***

Laboratories that receive large numbers of specimens should designate a particular room or area for this purpose.

#### ***Opening packages***

Personnel who receive and unpack specimens should be aware of the potential health hazards involved, and should be trained to adopt universal precautions (3), particularly when dealing with broken or leaking containers. Specimens should be unpacked in a biological safety cabinet. Disinfectants should be available.

### **Use of pipettes and pipetting aids**

1. A pipetting aid should always be used. Pipetting by mouth must be prohibited.
2. All pipettes should have cotton plugs to reduce contamination of pipetting devices.
3. Air should never be blown through a liquid containing infectious agents.
4. Infectious materials should not be mixed by alternate suction and expulsion through a pipette.
5. Liquids should not be forcibly expelled from pipettes.
6. Mark-to-mark pipettes are preferable to other types as they do not require expulsion of the last drop.
7. Contaminated pipettes should be completely submerged in a suitable disinfectant contained in an unbreakable container. They should be left in the disinfectant for 18-24 h before disposal.
8. A discard container for pipettes should be placed within the biological safety cabinet, not outside it.

9. Syringes fitted with hypodermic needles must not be used for pipetting. Blunt cannulas should be used instead of needles. There are devices for opening septum-capped bottles that allow pipettes to be used and avoid the use of hypodermic needles and syringes.
10. To avoid dispersion of infectious material accidentally dropped from a pipette, a disinfectant-soaked cloth or absorbent paper should be placed on the working surface; this should be autoclaved or discarded as infectious waste after use.

### **Avoiding the dispersal of infectious materials**

1. In order to avoid the premature shedding of their loads, microbiological transfer loops should have a diameter of 2–3 mm and be completely closed. The shanks should be not more than 6 cm in length to minimize vibration.
2. The risk of spatter of infectious material in an open Bunsen burner flame should be avoided by using an enclosed electric microincinerator to sterilize transfer loops. Disposable transfer loops, which do not need to be resterilized, are preferable.
3. Catalase tests should not be performed on slides to avoid bubbling and dispersal of aerosols. The tube, capillary tube or cover-glass methods should be used instead.
4. Discarded specimens and cultures for autoclaving and/or disposal should be placed in leakproof containers, e.g. laboratory discard bags.
5. Working areas must be decontaminated with a suitable disinfectant at the end of each work period.

For further information see reference 12.

### **Use of biological safety cabinets**

1. The use and limitations of biological safety cabinets should be explained to all potential users (see Chapter 7), with reference to national standards and relevant literature. Written protocols or safety or operations manuals should be issued to staff. In particular, it must be made clear that the cabinet will not protect the operator from spillage, breakage or poor technique.
2. The cabinet must not be used unless it is working properly.
3. The glass viewing panel must not be opened when the cabinet is in use.
4. Apparatus and materials in the cabinet must be kept to a minimum. Air circulation at the rear plenum must not be blocked. Materials should be surface-decontaminated before placing them inside the working area of the cabinet.
5. Bunsen burners must not be used in the cabinet. The heat produced will distort the air flow and may damage the filters. An electric microincinerator is permissible but sterile disposable transfer loops are better.
6. All work must be carried out in the middle or rear part of the working surface and be visible through the viewing panel.
7. Traffic behind the operator should be minimized.
8. The operator should not disturb the air flow by repeated removal and reintroduction of his or her arms.
9. The front air grill must not be blocked with notes, pipettes or other materials, as this will disrupt the air flow causing potential contamination of the material and exposure of the operator.
10. The surface of the biological safety cabinet should be wiped using an appropriate disinfectant after work is completed and at the end of the day.
11. The cabinet fan should be run for at least 5 min before beginning work and after completion of work in the cabinet.

For further information about biological safety cabinets see Chapter 7.

### **Avoiding ingestion of infectious materials and contact with skin and eyes**

1. Large particles and droplets (> 5  $\mu\text{m}$  in diameter) released during microbiological manipulations settle rapidly on bench surfaces and on the hands of the operator. Disposable gloves should be worn. Laboratory workers should avoid touching their mouth, eyes and face.
2. Food and drink must not be consumed or stored in the laboratory.
3. There should be no gum-chewing in the laboratory.



4. Cosmetics should not be applied in the laboratory.
5. The face, eyes and mouth should be shielded or otherwise protected during any operation that may result in the splashing of potentially infectious materials.

### **Avoiding injection of infectious materials**

1. Accidental inoculation with broken or chipped glassware can be avoided through careful practices and procedures. Glassware should be replaced with plastic ware whenever possible.
2. Injections may result from accidents with hypodermic needles (needle-sticks), glass Pasteur pipettes and broken glass.
3. Needle-stick accidents can be reduced by (a) taking particular care, and (b) minimizing the use of syringes and needles; for many techniques, syringes with blunt cannulas may be used instead. Simple devices are available for opening septum-stoppered bottles so that pipettes can be used.
4. Needles should never be recapped. Without disconnecting them from the syringe (if available), disposable articles should be discarded into puncture-proof containers fitted with covers.
5. Plastic Pasteur pipettes should replace those made of glass.

### **Separation of serum**

1. Only properly trained staff should be employed for this work.
2. Gloves and eye and mucous membrane protection should be worn.
3. Splashes and aerosols can only be avoided or minimized by good laboratory technique. Blood and serum should be pipetted carefully, not poured. Pipetting by mouth must be forbidden.
4. After use, pipettes should be completely submerged in hypochlorite or other suitable disinfectant. They should remain in the disinfectant for at least 18 h before disposal, or washing and sterilization for reuse.
5. Discarded specimen tubes containing blood clots, etc. (with caps replaced) should be placed in suitable leakproof containers for autoclaving and/or incineration.
6. A solution of hypochlorite, freshly prepared daily, should be available for clean-up of splashes and spillages (see Chapter 14).

### **Use of centrifuges**

1. Satisfactory mechanical performance is a prerequisite of microbiological safety in the use of laboratory centrifuges.
2. Centrifuges should be operated according to the manufacturer's instructions.
3. Centrifuges should be placed at such a level that workers of less than average height can see into the bowl to place trunnions and buckets correctly.
4. Centrifuge tubes and specimen containers for use in the centrifuge should be made of thick-walled glass or preferably of plastic and should be inspected for defects before use.
5. Tubes and specimen containers should always be securely capped (screw-capped if possible) for centrifugation.
6. The buckets must be loaded, equilibrated, sealed and opened in a biological safety cabinet.
7. Buckets and trunnions should be paired by weight and, with tubes in place, correctly balanced.
8. The amount of space that should be left between the level of the fluid and the rim of the centrifuge tube should be given in manufacturer's instructions.
9. Distilled water or alcohol (propanol, 70%) should be used for balancing empty buckets. Saline or hypochlorite solutions should not be used as they corrode metals.
10. Sealable centrifuge buckets (safety cups) must be used for microorganisms of Risk Groups 3 and 4.
11. When using angle head centrifuge rotors, care must be taken to ensure that the tube is not overloaded as it might leak.
12. The interior of the centrifuge bowl should be inspected daily for staining or soiling at the level of the rotor. If staining or soiling are evident then the centrifugation protocols should be re-evaluated.
13. Centrifuge rotors and buckets should be inspected daily for signs of corrosion and for hair-line cracks.
14. Buckets, rotors and centrifuge bowls should be decontaminated after each use.
15. After use, buckets should be stored in an inverted position to drain the balancing fluid.
16. Infectious airborne particles may be ejected when centrifuges are used. These particles travel at speeds too high to be retained by the cabinet air flow if the centrifuge is placed in a traditional open-

fronted Class I or Class II biological safety cabinet. Enclosing centrifuges in Class III safety cabinets prevents emitted aerosols from dispersing widely. However, good centrifuge technique and securely capped tubes offer adequate protection against infectious aerosols and dispersed particles.

### **Use of homogenizers, shakers, blenders and sonicators**

1. Domestic (kitchen) homogenizers should not be used in laboratories as they may leak or release aerosols. Laboratory blenders and stomachers are safer.
2. Caps and cups or bottles should be in good condition and free from flaws or distortion. Caps should be well-fitting and gaskets should be in good condition.
3. Pressure builds up in the vessel during the operation of homogenizers, shakers and sonicators. Aerosols containing infectious materials may escape from between the cap and the vessel. Plastic, in particular, polytetrafluoroethylene (PTFE) vessels are recommended because glass may break, releasing infectious material and possibly wounding the operator.
4. When in use, homogenizers, shakers and sonicators should be covered by a strong transparent plastic casing. This should be disinfected after use. Where possible, these machines should be operated, under their plastic covers, in a biological safety cabinet.
5. At the end of the operation the containers should be opened in a biological safety cabinet.
6. Hearing protection should be provided for people using sonicators.

### **Use of tissue grinders**

1. Glass grinders should be held in a wad of absorbent material in a gloved hand. Plastic (PTFE) grinders are safer.
2. Tissue grinders should be operated and opened in a biological safety cabinet.

### **Care and use of refrigerators and freezers**

1. Refrigerators, deep-freezers and solid carbon dioxide (dry-ice) chests should be defrosted and cleaned periodically, and any ampoules, tubes, etc. that have broken during storage removed. Face protection and heavy duty rubber gloves should be worn during cleaning. After cleaning, the inner surfaces of the cabinet should be disinfected.
2. All containers stored in refrigerators, etc. should be clearly labelled with the scientific name of the contents, the date stored and the name of the individual who stored them. Unlabelled and obsolete materials should be autoclaved and discarded.
3. An inventory must be maintained of the freezer's contents.
4. Flammable solutions must not be stored in a refrigerator unless it is explosion-proof. Notices to this effect should be placed on refrigerator doors.

### **Opening of ampoules containing lyophilized infectious materials**

Care should be taken when ampoules of freeze-dried materials are opened, as the contents may be under reduced pressure and the sudden inrush of air may disperse some of the materials into the atmosphere. Ampoules should always be opened in a biological safety cabinet. The following procedures are recommended for opening ampoules.

1. First decontaminate the outer surface of the ampoule.
2. Make a file mark on the tube near to the middle of the cotton or cellulose plug, if present
3. Hold the ampoule in a wad of alcohol-soaked cotton to protect hands before breaking it at a file scratch.
4. Remove the top gently and treat as contaminated material.
5. If the plug is still above the contents of the ampoule, remove it with sterile forceps.
6. Add liquid for resuspension slowly to the ampoule to avoid frothing.

## Storage of ampoules containing infectious materials

Ampoules containing infectious materials should never be immersed in liquid nitrogen because cracked or imperfectly sealed ampoules may break or explode on removal. If very low temperatures are required, ampoules should be stored only in the gaseous phase above the liquid nitrogen. Otherwise, infectious materials should be stored in mechanical deep-freeze cabinets or on dry ice. Laboratory workers should wear eye and hand protection when removing ampoules from cold storage.

The outer surfaces of ampoules stored in these ways should be disinfected when the ampoules are removed from storage.

## Special precautions with blood and other body fluids, tissues and excreta

The precautions outlined below are designed to protect laboratory workers against infection by bloodborne pathogens.

### *Collection, labelling and transport of specimens*

1. Universal precautions (3) should always be followed; gloves should be worn for all procedures.
2. Blood should be collected from patients and animals by trained staff.
3. For phlebotomies, conventional needle and syringe systems should be replaced by single-use safety vacuum devices that allow the collection of blood directly into stoppered transport and/or culture tubes, automatically disabling the needle after use.
4. The tubes should be placed in adequate containers for transport to the laboratory (see Chapter 12 for transport requirements) and within the laboratory facility (see Chapter 10). Request forms should be placed in separate water-proof bags or envelopes.
5. Reception staff should **not** open these bags.

### *Containment*

1. Diagnostic work may be done in a basic laboratory - Biosafety Level 2, preferably one dedicated for this purpose.
2. Research and development work involving propagation of large volumes or high concentrations of infectious microorganisms may require a containment laboratory - Biosafety Level 3 or higher containment level.

### *Opening specimen tubes and sampling contents*

1. Specimen tubes should be opened in a Class I or Class II biological safety cabinet.
2. Gloves must be worn. Eye and mucous membrane protection is also recommended (goggles or shield (visor)).
3. Protective clothing should be supplemented with a plastic apron.
4. The stopper should be grasped through a piece of paper or gauze to prevent splashing.

### *Glass and "sharps"*

1. Plastics should replace glass wherever possible. Only laboratory grade (borosilicate) glass should be used, and any article that is chipped or cracked should be discarded.
2. Hypodermic needles must not be used as pipettes. Blunt cannulas are permitted.

### *Films and smears for microscopy*

Fixing and staining of blood, sputum and faecal samples for microscopy does not necessarily kill all organisms or viruses on the smears. These items should be handled with forceps, stored appropriately, and decontaminated and/or autoclaved before disposal.

### *Automated equipment (sonicators, vortex mixers)*

1. Equipment should be of the closed type to avoid dispersion of droplets and aerosols.
2. Effluents should be collected in closed vessels for further autoclaving and/or disposal.

3. Equipment should be disinfected at the end of each session, following the manufacturer's instructions.

### **Tissues**

1. Formalin fixatives should be used. Small specimens, e.g. from needle biopsies, can be fixed and decontaminated within a few hours, but larger specimens may take several days.
2. Frozen sectioning should be avoided. Should it be essential, the cryostat should be shielded and the operator should wear a safety shield (visor). For decontamination, the temperature of the instrument should be raised to 20 °C.

### **Decontamination**

Hypochlorites and high-level disinfectants are recommended for decontamination. Freshly prepared hypochlorite solutions should contain available chlorine at 1 g/l for general use and 10 g/l for blood spillages. Glutaraldehyde may be used for decontaminating surfaces (see Chapter 14).

### **Precautions with materials that may contain prions**

Prions (also referred to as "slow viruses") are associated with certain transmissible spongiform encephalopathies (TSEs), notably Creutzfeldt-Jakob disease (CJD; including the new variant form), Gerstmann-Sträussler-Scheinker syndrome, fatal familial insomnia and kuru in humans; scrapie in sheep and goats; bovine spongiform encephalopathy (BSE) in cattle; and other transmissible encephalopathies of deer, elk and mink. Although CJD has been transmitted to humans, there appear to be no proven cases of laboratory-associated infections with any of these agents. Nevertheless, it is prudent to observe certain precautions in the handling of material from infected or potentially infected humans and animals.

The selection of a biosafety level for work with materials associated with TSEs will depend on the samples to be studied, and should be undertaken in consultation with national authorities. The highest concentrations of prions are found in central nervous system tissue. Animal studies suggest that it is likely that high concentrations of prions are also found in the spleen, thymus, lymph nodes and lung.

As there is no method that will ensure decontamination after exposure to prions, it is important to stress the use of disposable instruments whenever possible, and to use a protective covering for the work surface of the biological safety cabinet, which can also be disposed of after use.

The main precaution to be taken is to avoid ingestion of contaminated materials or puncture of the laboratory worker's skin. The following additional precautions should be taken, as the agents are not killed by the normal processes of laboratory disinfection and sterilization.

1. The use of dedicated equipment, i.e. equipment not shared with other laboratories, is highly recommended.
2. Disposable laboratory protective clothing (gowns and aprons) and gloves must be worn (steel mesh gloves between rubber gloves for pathologists).
3. Use of disposable plastic ware, which can be treated and discarded as dry waste, is highly recommended.
4. Tissue processors should not be used because of the problems of disinfection. Jars and beakers should be used instead.
5. All manipulations must be conducted in biological safety cabinets.
6. Great care should be exercised to avoid aerosol production, accidental ingestion, and cuts and punctures of the skin.
7. Formalin-fixed tissues should be regarded as still infectious, even after prolonged exposure to formalin.
8. Bench waste, including disposable gloves, gowns and aprons, should be autoclaved, followed by incineration.
9. Non-disposable instruments, including steel mesh gloves, must be collected for decontamination.
10. Infectious liquid waste contaminated with prions should be treated with 2 mol/l sodium hydroxide (final concentration) for 1 h followed by autoclaving
11. Paraformaldehyde vaporization procedures do not diminish prion titres and prions are resistant to ultraviolet irradiation. However, the cabinets must continue to be decontaminated by standard methods (i.e. formaldehyde gas) to inactivate other agents that may be present.

12. Prion-contaminated biological safety cabinets and other surfaces can be decontaminated by repeated wetting with 2 mol/l sodium hydroxide for 1 h followed by rinsing with water. High-efficiency particulate air (HEPA) filters should be autoclaved and incinerated at regular intervals.
13. Instruments should be soaked for 1 h in 2 mol/l sodium hydroxide and then rinsed well in water before autoclaving.
14. Instruments that cannot be autoclaved can be cleaned by repeated wetting with 2 mol/l sodium hydroxide over a 1-h period. Appropriate washing to remove residual sodium hydroxide is required.

For further information on the handling of unconventional agents see references 12, 22 and 23.

interim guidelines

# 11. Biosafety and recombinant DNA technology

Recombinant DNA technology involves combining genetic information from different sources thereby creating genetically modified organisms (GMOs) that may have never existed in nature before. Initially there was concern among molecular biologists that such organisms might have unpredictable and undesirable properties and would represent a biohazard if they escaped from the laboratory. This concern resulted in the famous Asilomar conference held in 1975 (24). At that meeting safety issues were discussed and the first guidelines for recombinant DNA technology were proposed. More than 25 years have now passed and no adverse incidents associated with this technology have been revealed. This demonstrates that genetic engineering is safe, provided that appropriate safety measures are observed.

Recombinant DNA technology or genetic engineering was first used to clone DNA segments of interest in bacterial hosts in order to produce enough sufficiently pure materials for further studies. More recently, recombinant DNA molecules have also been used to create genetically modified higher organisms such as transgenic and “knock-out” animals and transgenic plants (see the relevant sections below).

Recombinant DNA technology has already had an enormous impact on biology and medicine and will have an even greater influence in the near future. Now that the nucleotide sequence of the entire human genome is available, tens of thousands of genes of unknown functions will be studied, and recombinant DNA technology will be one of the means of doing so. Furthermore, gene therapy is expected to become an accepted treatment for certain diseases in the future, and many new vectors for gene transfer will be devised using genetic engineering techniques. Finally, transgenic plants produced by recombinant DNA technology may play an increasingly important role in modern agriculture.

When considering the use or construction of GMOs, the risk assessment process for work in the laboratory is perhaps even more important than that for work with genetically normal (non-modified) organisms. Whereas the latter are likely to be well-characterized with respect to pathogenic properties, the former will be novel, and evaluation of the potential hazards associated with working with such organisms cannot build on experience only.

The risk assessment will identify the biological containment system to be used. The properties of the donor organism, the nature of the DNA sequences that will be transferred, the properties of the recipient organism, and the properties of the environment must be evaluated. All of these factors will determine the biosafety level that is required for the safe handling of the resulting GMO. The following paragraphs provide some background information with respect to these criteria.

## Biological expression systems

Biological expression systems are vectors and host cells that fulfil a number of criteria that make them safe to use. A good example of a biological expression system is plasmid pUC18 (or derivatives thereof), which is frequently used as a cloning vector in combination with *Escherichia coli* K12 cells. The pUC18 plasmid and its derivatives have been entirely sequenced. More importantly, all genes required for efficient transfer to other bacteria have been deleted from the precursor plasmid pBR322 providing significant containment. *E. coli* K12 is a strain that lacks the genes known to render some *E. coli* strains pathogenic. Furthermore, *E. coli* K12 cannot permanently colonize the gut of healthy humans or animals. Thus, most routine genetic engineering experiments can be performed safely in *E. coli* K12/pUC18 at Biosafety Level 1 provided the inserted foreign DNA sequences do not require a higher biosafety level (see below).

## Properties of the donor organism and cloned DNA

Risk assessment must consider not only the vector/host system used but also the properties of the DNA to be cloned. In most cases the risk assessment will show that the inserted DNA sequences are unlikely to alter the biological properties of the host organism, but in some cases they may do so, for example, if they are derived from a pathogenic organism. Obviously not all genes of a pathogenic organism

contribute to the virulence of the agent. Therefore, insertion of well-characterized DNA sequences that are unlikely to be involved in pathogenicity may not require additional safety measures. However, in cases where these sequences are not characterized, a situation that is typically encountered when a library of genomic DNA of an organism is being established, a higher biosafety level will be required.

An important consideration is whether the gene product has potential pharmacological activity. Cloning of genes coding for proteins such as toxins may therefore require higher biosafety levels. Over-expression of gene products from eukaryotic viral vectors can have unexpected consequences when these proteins have pharmacological activity.

### **Viral vectors for gene transfer**

Viral vectors are used not only for gene therapy but also for efficient transfer of genes to other cells. Adenovirus vectors have become popular for gene therapy. Such vectors lack certain genes that are required for virus replication and therefore have to be propagated in cell lines that complement the defect. Although such vectors are replication-defective, they should be handled at the same biosafety level as the parent adenovirus from which they are derived. The reason for this is that the virus stocks may be contaminated with replication-competent viruses, which are generated by rare spontaneous recombination events in the complementing cell line.

### **Transgenic and “knock-out” animals**

Animals carrying foreign genetic information (transgenic animals) should be handled in containment levels appropriate to the characteristics of the products of the foreign genes. Animals with targeted deletions of specific genes (“knock-out” animals) do not generally present particular biological hazards.

Examples of transgenic animals include animals expressing receptors for viruses normally unable to infect that species. If such animals escaped from the laboratory and transmitted the transgene to the wild animal population, an animal reservoir for that particular virus could theoretically be generated.

This possibility has been discussed for poliovirus and is particularly relevant in the context of poliomyelitis eradication.

Transgenic mice expressing the human poliovirus receptor generated in different laboratories were susceptible to poliovirus infection by various inoculation routes and the resulting disease was clinically and histopathologically similar to human poliomyelitis. However, the mouse model differs from humans in that alimentary tract replication of orally administered poliovirus is either inefficient or does not occur. It is therefore very unlikely that escape of such transgenic mice to the wild would result in the establishment of a new animal reservoir for poliovirus. Nevertheless, this example indicates that, for each new line of transgenic animal, detailed studies should be conducted to determine the routes by which the animals can be infected, the inoculum size required for infection, and the extent of virus shedding by the infected animals. In addition, all measures should be taken to assure strict containment of receptor transgenic mice.

### **Transgenic plants**

Transgenic plants expressing genes that confer tolerance to herbicides or resistance to insects are currently a matter of considerable controversy in large parts of the world. The discussions mainly focus on the safety of such plants as food and on the long-term ecological consequences of growing such plants on a large scale, which are not the subjects of this chapter.

Transgenic plants expressing genes of animal or human origin should remain strictly contained within the facility. Such transgenic plants should be handled at biosafety levels appropriate to the characteristics of the products of the expressed genes.

### **Conclusions**

When creating or handling recombinant organisms, it is essential to perform a detailed risk assessment, which must take into account the nature of the donor, the recipient organism and the environment. In many cases the risk assessment will show that the recombinant organism can be handled at the same biosafety level as the wild-type recipient. In some instances, however, higher biosafety levels will be required. This is the case, for example, when ill-defined DNA sequences from a donor organism are

transferred, which could potentially increase the virulence of the recipient organism. This situation is typically encountered in random (“shot-gun”) cloning experiments in which genomic DNA libraries are established. Risk assessment is particularly important when creating GMOs expressing proteins with pharmacological activity, such as toxins. It is obvious that such organisms must be handled with caution. Some pharmacologically active proteins are only toxic when expressed at high levels. In this case, the risk assessment becomes very demanding and requires an estimation of the expected expression levels of the protein by a particular recombinant organism and the levels at which a given protein becomes toxic in an organism accidentally exposed to it. Many countries have national safety committees, which establish guidelines for work with GMOs and help scientists classify their work at the appropriate biosafety level. In some cases classification may differ between countries, or countries may decide to classify work at a lower or higher level when new information on a particular vector/host system becomes available. Risk assessment is thus a dynamic process and has to take into account new developments and the progress of science. It is the responsibility of the scientists involved in genetic engineering to keep up to date on these developments, and to respect the guidelines established by their national safety committee.

For further information see references 25-27.

interim guidelines



## 12. Transport of infectious substances

International regulations for the transport of infectious materials are based on the biennial recommendations of the United Nations Committee of Experts on the Transport of Dangerous Goods. In December 2002, at the end of the current biennium 2001-2002, the Committee may introduce further changes to a proposal to amend the current requirements in the United Nations Transport of Dangerous Goods – Model Regulations that has been recently accepted at a biannual session. The proposal that has been adopted, and the further changes that may be introduced, will substantially affect the current regulations concerning the transport of infectious substances. Chapter 12 on “Transport of infectious substances” is therefore awaiting the final vote to be taken in December 2002 by the Committee.

The *Laboratory biosafety manual*, 3rd ed., which will include the revised Chapter 12, will be made available on the WHO web site and published in 2003.

interim guidelines

## 13. Contingency plans and emergency procedures

Every laboratory that works with infective microorganisms should institute safety precautions appropriate to the hazard of the organisms and the animals being handled.

A written contingency plan for dealing with laboratory and animal facility accidents is a necessity in any facility that works with or stores Risk Group 3 or 4 microorganisms (containment laboratory – Biosafety Level 3 and maximum containment laboratory – Biosafety Level 4). National and/or local health authorities should be involved in the development of the emergency preparedness plan.

### Contingency plan

The contingency plan should provide operational procedures for:

- precautions against natural disasters, e.g. fire, flood, earthquake, and explosion
- biohazard risk assessment
- accident-exposure management and decontamination
- emergency evacuation of people and animals from the premises
- emergency medical treatment of exposed and injured persons
- medical surveillance of exposed persons
- clinical management of exposed persons
- epidemiological investigation.

In the development of this plan the following items should be considered for inclusion:

- identification of high-risk organisms
- location of high-risk areas, e.g. laboratories, storage areas, animal facilities
- identification of at-risk personnel and populations
- identification of responsible personnel and their duties, e.g. biosafety officer, safety personnel, local health authority, clinicians, microbiologists, veterinarians, epidemiologists, and fire and police services
- lists of treatment and isolation facilities that can receive exposed or infected persons
- transport of exposed or infected persons
- lists of sources of immune serum, vaccines, drugs, special equipment and supplies
- provision of emergency equipment, e.g. protective clothing, disinfectants, decontamination equipment.

### Emergency procedures for microbiological laboratories

#### ***Accidental injection, cuts and abrasions***

The affected individual should remove protective clothing, wash the hands and the affected part, apply an appropriate skin disinfectant, go to the first-aid room, and inform the person in charge about the cause of the wound and the organisms involved. If considered necessary, a physician should be consulted and his or her advice followed. Appropriate and complete medical records should be kept.

#### ***Accidental ingestion of potentially hazardous material***

Protective clothing should be removed and the individual taken to the first-aid room. A physician should be informed of the material ingested and his or her advice followed. Appropriate and complete medical records should be kept.

***Potentially hazardous aerosol release (other than in a biological safety cabinet)***

All persons should immediately vacate the affected area and any exposed persons should be referred for medical advice. The laboratory supervisor and the biosafety officer should be informed at once. No one should enter the room for at least 1 h, to allow aerosols to be carried away and heavier particles to settle. If the laboratory does not have a central air exhaust system, entrance should be delayed for 24 h. Signs should be posted indicating that entry is forbidden. After the appropriate time, decontamination should proceed, supervised by the biosafety officer. Appropriate protective clothing and respiratory protection should be worn for this.

***Broken and spilled infectious substances, including cultures***

Broken objects contaminated with infectious substances, including vials or containers, or spilled infectious substances, including cultures, should be covered with a cloth or paper towels. Disinfectant should then be poured over these and left for at least 30 min. The cloth or paper towels and the broken material may then be cleared away; glass fragments should be handled with forceps. The contaminated area should then be swabbed with disinfectant. If dustpans are used to clear away the broken material, they should be autoclaved or placed in an effective disinfectant for 24 h. Cloths, paper towels and swabs used for cleaning up should be placed in a contaminated-waste container. Gloves should be worn for all these procedures.

If laboratory forms or other printed or written matter are contaminated, the information should be copied onto another form and the original discarded into the contaminated-waste container.

***Breakage of tubes containing potentially hazardous material in centrifuges not having sealable buckets***

If a breakage occurs or is suspected while the machine is running, the motor should be switched off and the machine left closed for 30 min. If a breakage is discovered after the machine has stopped, the lid should be replaced immediately and left closed for 30 min. In both instances, the biosafety officer should be informed.

Strong (e.g. thick rubber) gloves, covered if necessary with suitable disposable gloves, should be worn for all subsequent operations. Forceps, or cotton held in the forceps, should be used to retrieve glass debris.

All broken tubes, glass fragments, buckets, trunnions and the rotor should be placed in noncorrosive disinfectant known to be active against the organisms concerned and left for 24 h and/or autoclaved. Unbroken, capped tubes may be placed in disinfectant in a separate container and recovered after 60 min.

The centrifuge bowl should be swabbed with the same disinfectant, at the appropriate dilution, left overnight and then swabbed again, washed with water and dried. All materials used in the clean-up should be treated as infectious waste.

***Breakage of tubes inside sealable buckets (safety cups)***

All sealed centrifuge buckets should be loaded and unloaded in a biological safety cabinet. If a breakage is suspected, the cap should be opened and left loose and the bucket autoclaved.

***Fire, flood and natural disaster***

Fire and other services should be involved in the development of emergency plans. They should be told in advance which rooms contain potentially infectious materials. It is beneficial to arrange for these services to visit the laboratory to become acquainted with its layout and contents if possible.

After a flood or other natural disaster (including earthquake), local or national emergency services should be warned of the potential hazards within and/or near laboratory buildings. They should enter only when accompanied by a trained laboratory worker. Cultures and infectious materials should be collected in leakproof boxes or strong disposable bags. Salvage or final disposal should be determined by safety staff on the basis of local knowledge.

## **Vandalism**

Vandalism is usually selective (e.g. aimed at animal houses). Suitable defences are strong, heavy doors, good locks and restricted entry. Screened windows and intruder alarms are desirable. Action after vandalism is the same as that for other emergencies.

## **Emergency services: whom to contact**

The telephone numbers and addresses of the following should be prominently displayed near all telephones:

- the institution or laboratory itself (the address and location may not be known in detail by the caller or the services called)
- director of the institution or laboratory
- laboratory supervisor
- biosafety officer
- fire services
- hospital/ambulance service (if a particular hospital has arranged to accept casualties, e.g. high-risk personnel, the names of individual departments and doctors)
- police
- medical officer
- responsible technician
- water, gas and electricity services.

## **Emergency equipment**

The following emergency equipment must be available:

- first-aid kit, including universal and special antidotes
- stretcher
- appropriate fire extinguishers, fire blankets

The following are also suggested but may be varied according to local circumstances:

- full protective clothing (one-piece coveralls, gloves and head covering – for incidents involving microorganisms in Risk Groups 3 and 4)
- full-face respirators with appropriate chemical and particulate filter canisters
- room disinfection apparatus, e.g. sprays and formaldehyde vaporizers
- tools, e.g. hammers, axes, spanners, screwdrivers, ladders, ropes
- hazard area demarcation equipment and notices.

For further information see references 12 and 28.

## 14. Disinfection and sterilization

A basic knowledge of disinfection and sterilization is crucial for biosafety in the laboratory. Since heavily soiled items cannot promptly be efficiently disinfected or sterilized, it is equally important to understand the fundamentals of precleaning. In this regard, the following general principles apply to all known classes of microbial pathogens, with the notable exception of prions, which are dealt with separately in this chapter.

The specific requirements for decontamination for biosafety will depend on the type of experimental work and the nature of the infectious agent(s) being handled. It will, therefore, be necessary to use the generic information given here to develop more specific and standardized procedures to suit the needs of the various levels of biohazard involved in a particular laboratory.

### Definitions

Many different terms are used in dealing with the process of decontamination for biosafety. The following are among the more common.

|                           |   |
|---------------------------|---|
| <b>Antimicrobial</b>      | An agent that kills microorganisms or suppresses their growth and multiplication.   |
| <b>Antiseptic</b>         | A substance that inhibits the growth and development of microorganisms without necessarily killing them. Antiseptics are usually applied on body surfaces.            |
| <b>Biocide</b>            | A general term for any agent that kills unicellular and multicellular organisms.  |
| <b>Chemical germicide</b> | A chemical or a mixture of chemicals used to kill microorganisms.   |
| <b>Decontamination</b>    | Any process for removing and/or killing microorganisms. The same term is also used for removing or neutralizing hazardous chemicals and radioactive materials.        |
| <b>Disinfectant</b>       | A chemical or mixture of chemicals used to kill microorganisms, but not necessarily their spores. Disinfectants are usually applied on inanimate surfaces or objects. |
| <b>Disinfection</b>       | A physical or chemical means of killing microorganisms, but not necessarily their spores.   |
| <b>Microbicide</b>        | A chemical or mixture of chemicals that kills microorganisms. The term is often used in place of "biocide", "germicide" or "antimicrobial".                           |
| <b>Sterilization</b>      | A process that destroys and/or removes all classes of microorganisms and their spores.  |

### Precleaning and cleaning laboratory materials

In practical terms, cleaning is the removal of visible dirt and stains. This is generally achieved either by (a) brushing, vacuuming or dry dusting; or (b) washing or damp mopping with water containing a soap or detergent. Where the risk of human or animal contact with pathogen-contaminated materials is high and subsequent decontamination is needed, precleaning is routinely carried out. This is necessary because dirt and soil can shield microorganisms and can also interfere with the killing action of chemical germicides. In such cases, precleaning is essential to achieve proper disinfection or sterilization. Also, many germicidal products claim activity only on precleaned items. Precleaning must be carried out with care to avoid exposure to infectious agents, and materials chemically compatible with the germicides to be applied later must be used. It is quite common to use the same chemical germicide for precleaning and disinfection.

## Chemical germicides

Many types of chemicals can be used as disinfectants and antiseptics and there is an ever-increasing number and variety of commercial products. Formulations must therefore be carefully selected for specific needs, and stored, used and disposed of as directed by the manufacturer. The germicidal activity of many chemicals is faster and better at higher temperatures. At the same time, higher temperatures can accelerate their evaporation and also degrade them faster. Particular care is needed in the use and storage of such chemicals in tropical regions, where their shelf-life may be reduced because of high ambient temperatures.

Many germicides can be harmful to humans and the environment. They should therefore be selected, handled and disposed of with care. For personal safety, gloves, aprons and eye protection are recommended when preparing use-dilutions of chemical germicides. Chemical germicides are therefore not required for regular and general cleaning of floors, walls, equipment and furniture except in cases of outbreak control.

Commonly used classes of chemical germicides are described below, with generic information on their applications and safety profiles. Unless otherwise indicated, the germicide concentrations are given in weight/volume (w/v). Table 10 summarizes the recommended dilutions of chlorine-releasing compounds.

**Table 10. Recommended dilutions of chlorine-releasing compounds**

|   | “Clean” conditions <sup>a</sup> | “Dirty” conditions <sup>b</sup> |
|---|---------------------------------|---------------------------------|
| Available chlorine required   | 0.1% (1 g/l)                    | 0.5% (5 g/l)                    |
| Sodium hypochlorite solution (5% available chlorine)                      | 20 ml/l                         | 100 ml/l                        |
| Calcium hypochlorite (70% available chlorine)                             | 1.4 g/l                         | 7.0 g/l                         |
| Sodium dichloroisocyanurate powder (60% available chlorine)               | 1.7 g/l                         | 8.5 g/l                         |
| Sodium dichloroisocyanurate tablets (1.5 g available chlorine per tablet) | 1 tablet per litre              | 4 tablets per litre             |
| Chloramine (25% available chlorine) <sup>c</sup>                          | 20 g/l                          | 20 g/l                          |

<sup>a</sup> After removal of bulk material.

<sup>b</sup> For flooding, e.g. on blood or before removal of bulk material.

<sup>c</sup> See text.

### **Chlorine (sodium hypochlorite)**

Chlorine, a fast-acting oxidant, is a widely available and broad-spectrum germicide. It is normally sold as bleach, an aqueous solution of sodium hypochlorite (NaOCl), which can be diluted with water to provide various concentrations of available chlorine.

Chlorine, especially as bleach, is highly alkaline and can be corrosive to metal. Its activity is considerably reduced by organic matter (protein). Storage of stock or working solutions of bleach in open containers, particularly at high temperatures, releases chlorine gas thus weakening their germicidal potential. The frequency with which working solutions of bleach should be changed depends on their starting strength, the type (e.g. with or without a lid) and size of their containers, the frequency and nature of use, and ambient conditions. As a general guide, solutions receiving materials with high levels of organic matter several times a day should be changed at least daily, while those with less frequent use may last for as long as a week.

A general all-purpose laboratory disinfectant should have a concentration of 1 g/l available chlorine. A stronger solution, containing 5 g/l available chlorine is recommended for dealing with biohazardous spillage and in the presence of large amounts of organic matter. Sodium hypochlorite containing 5 g/l available chlorine is recommended as the disinfectant of choice in emergency situations involving viruses such as Hantavirus, and Lassa and Ebola viruses.

Sodium hypochlorite solutions, as domestic bleach, contain 50 g/l available chlorine and should therefore be diluted 1:50 or 1:10 to obtain final concentrations of 1 g/l and 5 g/l, respectively. Industrial solutions of bleach have a sodium hypochlorite concentration of nearly 120 g/l and must be diluted accordingly to obtain the levels indicated above.

Granules or tablets of calcium hypochlorite ( $\text{Ca}(\text{ClO})_2$ ) generally contain about 70% available chlorine. Solutions prepared with granules or tablets, containing 1.4 g/l and 7.0 g/l, will then contain 1.0 g/l and 5 g/l available chlorine, respectively.

Bleach is not recommended as an antiseptic, but may be used as a general-purpose disinfectant and for soaking contaminated metal-free materials. In emergencies, bleach can also be used to disinfect water for drinking with a final concentration of 1–2 mg/l available chlorine.

**Note.** Chlorine gas is highly toxic. Bleach must therefore be stored and used in well-ventilated areas only. Also, bleach must not be mixed with acids in order to avoid the rapid release of chlorine gas. Many by-products of chlorine can be harmful to humans and the environment, so that indiscriminate use of chlorine-based disinfectants, and in particular bleach, should be avoided.

### **Sodium dichloroisocyanurate**

Sodium dichloroisocyanurate (NaDCC) in powder form contains 60% available chlorine. Solutions prepared with NaDCC powder at 1.7 g/l and 8.5 g/l will contain 1 g/l or 5 g/l available chlorine, respectively. Tablets of NaDCC generally contain the equivalent of 1.5 g available chlorine per tablet. One or four tablets dissolved in 1 litre of water will give the required concentrations of 1 g/l or 5 g/l, respectively. NaDCC as powder or tablets is easy and safe to store. Solid NaDCC can be applied on spills of blood or other biohazardous liquids and left for at least 10 min before removal. Further cleaning of the affected area can then take place.

### **Chloramines**

Chloramines are available as powders containing about 25% available chlorine. Chloramines release chlorine at a slower rate than hypochlorites. Higher initial concentrations are therefore required for efficiencies equivalent to those of hypochlorites. On the other hand, chloramine solutions are not inactivated by organic matter to the same extent as hypochlorite solutions, and concentrations of 20 g/l are recommended for both “clean” and “dirty” situations.

Chloramine solutions are virtually odour-free. However, items soaked in them must be thoroughly rinsed to remove any residue of the bulking agents added to chloramine-T (sodium tosylchloramide) powders. Chloramines can also be used to disinfect water for drinking when used at a final concentration of 1–2 mg/l available chlorine.

### **Chlorine dioxide**

Chlorine dioxide is a strong and fast-acting germicide, often reported to be active at levels lower than those needed by chlorine as bleach. To obtain an active solution for laboratory use it is generally necessary to mix two separate components, hydrochloric acid (HCl) and sodium chlorite ( $\text{NaClO}_2$ ). Stability can be an important issue with this germicide, and materials compatibility and corrosiveness must also be considered when selecting products based on it.

### **Formaldehyde**

Formaldehyde (HCHO) is a gas that kills all microorganisms and their spores, at temperatures above 20 °C. Formaldehyde is not active against prions. It is relatively slow-acting and needs a relative humidity level of about 70%. It is marketed as the solid polymer, paraformaldehyde, in flakes or tablets, or as formalin, a solution of the gas in water of about 370 g/l (37%), containing methanol (100 ml/l) as a stabilizer. Both formulations are heated to liberate the gas, which is used for decontamination and disinfection of enclosed volumes such as safety cabinets and rooms (see section on Local environmental decontamination, below).

Formaldehyde (5% formalin in water) may be used as a liquid disinfectant.

**Note.** Formaldehyde is a suspected carcinogen. It has a pungent smell and its fumes can irritate eyes and mucous membranes. It must therefore be stored and used in a fume-hood or well-ventilated areas. Applicable regulations on chemical safety must be consulted prior to its use.

### **Glutaraldehyde**

Like formaldehyde, glutaraldehyde ( $\text{OHC}(\text{CH}_2)_3\text{CHO}$ ) is also active against vegetative bacteria, spores, fungi and lipid- and nonlipid-containing viruses. It is non-corrosive and faster acting than formaldehyde. However, it takes several hours to kill bacterial spores. It is generally supplied as a solution with a concentration of about 20 g/l (2%) and most products need to be “activated” (made alkaline) before use by the addition of a bicarbonate compound supplied with the product. The activated solution can be reused for 1–4 weeks depending on the formulation and type and frequency of its use. Dipsticks supplied

with some products give only a rough indication of the levels of active glutaraldehyde available in solutions under use. Glutaraldehyde solutions should be discarded if they become turbid.

**Note.** Glutaraldehyde is toxic and an irritant to skin and mucous membranes, and contact with it must be avoided. It must be used in a fume-hood or in well-ventilated areas. It is not recommended as a spray or solution for the decontamination of environmental surfaces. Applicable regulations on chemical safety must be consulted prior to its use.

### ***Phenolic compounds***

Phenolic compounds, a broad group of agents, were among the earliest germicides. However, results of more recent safety concerns restrict their use. They are active against vegetative bacteria and lipid-containing viruses and, when properly formulated, also show activity against mycobacteria. They are not active against spores and their activity against nonlipid viruses is variable. Many phenolic products are used for the decontamination of environmental surfaces, and some (e.g. triclosan and chloroxylenol) are among the more commonly used antiseptics.

Triclosan is common in products for hand-washing. It is active mainly against vegetative bacteria and safe for skin and mucous membranes. However, in laboratory-based studies, bacteria made resistant to low concentrations of triclosan also show resistance to certain types of antibiotics. The significance of this finding in the field remains unknown.

**Note.** Phenolic compounds are not recommended for use on food contact surfaces and in areas with young children. They may be absorbed by rubber and can also penetrate the skin.

### ***Quaternary ammonium compounds***

Many types of quaternary ammonium compounds are used as mixtures and often in combination with other germicides, such as alcohols. They have good activity against vegetative bacteria and lipid-containing viruses. Certain types (e.g. benzalkonium chloride) are used as antiseptics.

**Note.** The germicidal activity of certain types of quaternary ammonium compounds is considerably reduced by organic matter, water hardness and anionic detergents. Care is therefore needed in selecting agents for precleaning when quaternary ammonium compounds are to be used for disinfection. Potentially harmful bacteria can grow in quaternary ammonium compound solutions. Owing to low biodegradability, these compounds may also accumulate in the environment.

### ***Alcohols***

Ethanol (ethyl alcohol,  $C_2H_5OH$ ) and 2-propanol (isopropyl alcohol,  $(CH_3)_2CHOH$ ) have similar disinfectant properties. They are active against vegetative bacteria, fungi and lipid-containing viruses but not against spores. Their action on nonlipid viruses is variable. For highest effectiveness they should be used at concentrations of approximately 70% (v/v) in water: higher or lower concentrations may not be as germicidal. A major advantage of aqueous solutions of alcohols is that they do not leave any residue on treated items.

Mixtures with other agents are more effective than alcohol alone, e.g. 70% (v/v) alcohol with 100 g/l formaldehyde, and alcohol containing 2 g/l available chlorine. A 70% (v/v) aqueous solution of ethanol can be used on skin, work surfaces of laboratory benches and biosafety cabinets, and to soak small pieces of surgical instruments. The contact time on skin should be no less than 10 s and that on environmental surfaces no less than 3 min. Since ethanol can dry the skin, it is often mixed with emollients. Alcohol-based hand-rubs are recommended for the decontamination of lightly soiled hands in situations where proper hand-washing is inconvenient or not possible. However, it must be remembered that ethanol is ineffective against spores and may not kill all types of nonlipid viruses.

**Note.** Alcohols are volatile and flammable and must not be used near open flames. Working solutions should be stored in proper containers to avoid the evaporation of alcohols. Alcohols may harden rubber and dissolve certain types of glue. Proper inventory and storage of ethanol in the laboratory is very important to avoid its use for purposes other than disinfection. The availability and use of ethanol in certain regions may be restricted owing to religious reasons. Bottles with alcohol-containing solutions must be clearly labelled to avoid their accidental autoclaving.

### ***Iodine and iodophors***

The action of these disinfectants is similar to that of chlorine, although they may be slightly less inhibited by organic matter. Iodine can stain fabrics and environmental surfaces and is generally unsuitable for use as a disinfectant. On the other hand, iodophors and tinctures of iodine are good antiseptics. Polyvidone-iodine is a reliable and safe surgical scrub and preoperative skin antiseptic. Antiseptics based on iodine are generally unsuitable for use on medical/dental devices. Iodine should not be used on aluminium or copper.



**Note.** Iodine can be toxic. Organic iodine-based products must be stored at 4–10 °C to avoid the growth of potentially harmful bacteria in them.

### **Hydrogen peroxide and peracids**

Like chlorine, hydrogen peroxide (H<sub>2</sub>O<sub>2</sub>) and peracids are strong oxidants and can be potent broad-spectrum germicides. They are also safer than chlorine to humans and the environment.

Hydrogen peroxide is supplied either as a ready-to-use 3% solution or as a 30% aqueous solution to be diluted to 5–10 times its volume with sterilized water. However, such 3–6% solutions of hydrogen peroxide alone are relatively slow and limited as germicides. Products now available have other ingredients to stabilize the hydrogen peroxide content, to accelerate its germicidal action and to make it less corrosive.

Hydrogen peroxide can be used for the decontamination of work surfaces of laboratory benches and biosafety cabinets, and stronger solutions may be suitable for disinfecting heat-sensitive medical/dental devices. The use of vaporized hydrogen peroxide or peracetic acid (CH<sub>3</sub>COOOH) for the decontamination of heat-sensitive medical/surgical devices requires specialized equipment.

**Note.** Hydrogen peroxide and peracids can be corrosive to metals such as aluminium, copper, brass and zinc, and can also decolorize fabrics, hair, skin and mucous membranes. Articles treated with them must be thoroughly rinsed before contact with eyes and mucous membranes. They should always be stored away from heat and protected from light.

## **Local environmental decontamination**

Decontamination of the laboratory space, its furniture and its equipment requires a combination of liquid and gaseous disinfectants. Surfaces can be decontaminated using a solution of sodium hypochlorite (NaOCl); a solution containing 1 g/l available chlorine may be suitable for general environmental sanitation, but stronger solutions (5 g/l) are recommended when dealing with high-risk situations. For environmental decontamination, formulated solutions containing 3% hydrogen peroxide (H<sub>2</sub>O<sub>2</sub>) make suitable substitutes for bleach solutions.

Rooms and equipment can be decontaminated by fumigation with formaldehyde gas generated by heating paraformaldehyde or boiling formalin. All openings in the room (i.e. windows, doors, etc.) should be sealed with masking tape or similar before the gas is generated. Fumigation should be conducted at an ambient temperature of at least 21 °C and a relative humidity of 70%. (See also section on Decontamination of biological safety cabinets, below.)

The gas should be in contact with the surfaces to be decontaminated for at least 8 h. After fumigation the area must be ventilated thoroughly before personnel are allowed to enter. Appropriate respirators must be worn by anyone entering the room before it has been ventilated. Gaseous ammonium bicarbonate can be used to neutralize the formaldehyde.

Fumigation of spaces with vapours of solution of hydrogen peroxide has been reported but requires further study.

**Note.** Formaldehyde is a dangerous and irritant gas and is a suspected carcinogen. Full-face respirators with air supply may be necessary. The “two-person” rule should apply.

## **Decontamination of biological safety cabinets**

To decontaminate Class I and Class II cabinets, the appropriate amount of paraformaldehyde (final concentration of 0.8% paraformaldehyde in air) should be placed on an electric hot plate or fry pan (controlled from outside the cabinet). A second hot plate or fry pan containing 10% more ammonium bicarbonate than paraformaldehyde (with controls outside the cabinet) is also placed inside the cabinet. This second pan should have a cover over it that can be removed remotely (e.g., attached to a string that can be pulled from outside the cabinet). This will minimize premature neutralization of the formaldehyde gas.

If the relative humidity is below 70%, an open container of hot water should also be placed inside the cabinet before the front closure is sealed in place with strong tape (e.g., “duct tape”). If there is no front closure, heavy gauge plastic sheeting is taped over the front to make sure that the gas cannot seep into the room.

The switch for the paraformaldehyde pan is turned on, then off 1 h later, or when the paraformaldehyde has all vaporized. The cabinet is left undisturbed overnight. The second pan is turned on after the cover is removed and the ammonium bicarbonate is allowed to vaporize. At that time, the pan

is turned off and the cabinet is turned on and allowed to circulate the ammonium bicarbonate gas for 1 h. The front closure (or plastic sheeting) can then be removed and the cabinet used.

## Hand-washing/hand decontamination

Whenever possible, suitable gloves should be worn when handling biohazardous materials. However, this does not replace the need for regular and proper hand-washing by laboratory personnel. Hands must be washed after handling biohazardous materials and animals, and using the toilet, and before leaving the laboratory, and eating.

In most situations, thorough washing of hands with ordinary soap and water is sufficient to decontaminate them, but the use of germicidal soaps is recommended in high-risk situations. Hands should be thoroughly lathered with soap, using friction, for at least 10 s, rinsed in clean water and dried using a clean paper or cloth towel (if available, warm-air hand-dryers are also recommended).

Foot- or elbow-operated faucets are recommended. Where not fitted, a paper/cloth towel should be used to turn off the faucet handles to avoid recontaminating washed hands.

As mentioned above, alcohol-based hand-rubs should be used to decontaminate lightly soiled hands when proper hand-washing is not available or not convenient.

## Heat disinfection and sterilization

Heat is the most common among the physical agents used for the decontamination of pathogens. “Dry” heat, which is totally non-corrosive, is used to process many items of laboratory ware which can withstand temperatures of 160 °C or higher for 2–4 h. Burning or incineration (see below) is also a form of dry heat. “Moist” heat is most effective when used in the form of autoclaving.

Boiling does not necessarily kill all microorganisms and/or pathogens, but it may be used as the minimum processing for disinfection where other methods (chemical disinfection or decontamination, autoclaving) are not applicable or available.

Sterilized items must be handled and stored such that they remain uncontaminated until used.

### Autoclaving

Saturated steam under pressure (autoclaving) is the most effective and reliable means of sterilizing laboratory materials. For most purposes, the following cycles will ensure sterilization of correctly loaded autoclaves:

- 3 min holding time at 134 °C
- 10 min holding time at 126 °C
- 15 min holding time at 121 °C
- 25 min holding time at 115 °C.

Examples of different autoclaves include the following.

*Gravity displacement autoclaves.* Fig. 7 shows the general construction of a gravity-displacement autoclave. Steam enters the chamber under pressure and displaces the heavier air downwards and through the valve in the chamber drain, fitted with a HEPA filter.

*Pre-vacuum autoclaves.* These machines allow the removal of air from the chamber before steam is admitted. The exhaust air is evacuated through a valve fitted with a HEPA filter. At the end of the cycle, the steam is automatically exhausted. These autoclaves can operate at 134 °C and the sterilization cycle can therefore be reduced to 3 min. They are ideal for porous loads, but cannot be used to process liquids because of the vacuum.

*Fuel-heated pressure cooker autoclaves.* These should be used only if a gravity displacement autoclave is not available. They are loaded from the top and heated by gas, electricity or other types of fuels. Steam is generated by heating water in the base of the vessel and air is displaced upwards through a relief vent. When all the air has been removed, the valve on the relief vent is closed and the heat reduced. The pressure and temperature rise until the safety valve operates at a preset level. This is the start of the holding time. At the end of the cycle the heat is turned off and the temperature allowed to fall to 80 °C or below before the lid is opened.

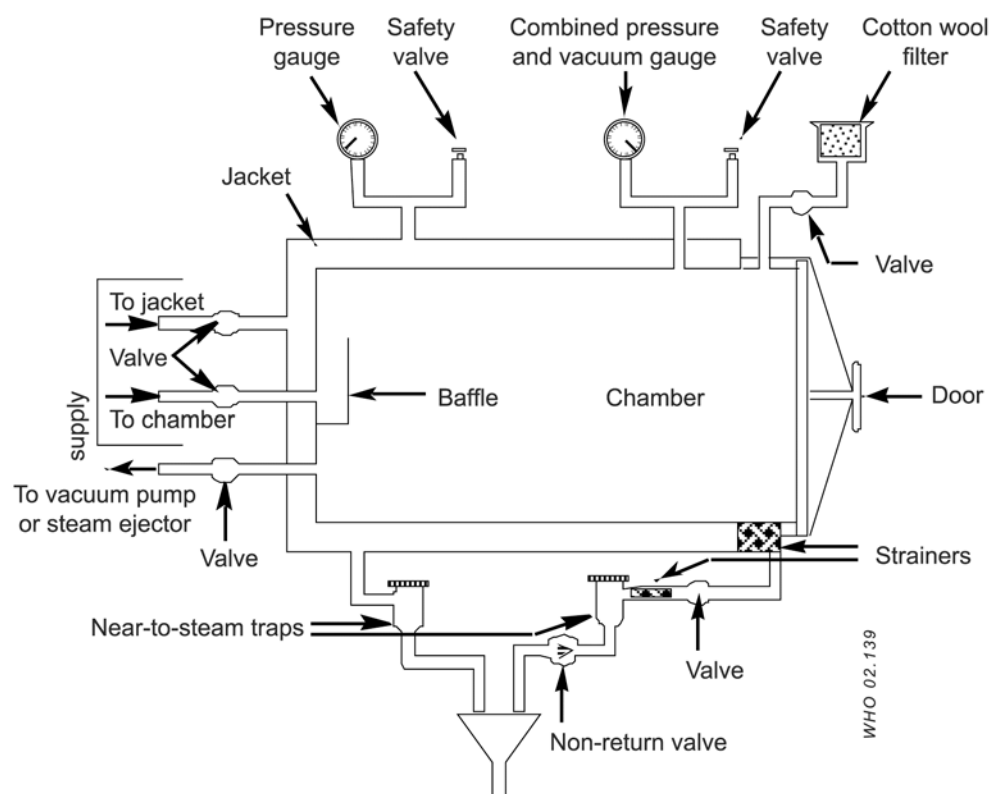

**Fig. 7. Gravity displacement autoclave**

#### *Loading autoclaves*

Materials should be loosely packed in the chamber for easy steam penetration and air removal. Bags should allow the steam to reach their contents.

#### *Precautions in the use of autoclaves*

The following rules can minimize the hazards inherent in operating pressurized vessels.

1. Responsibility for operation and routine care should be assigned to trained individuals and a preventive maintenance programme should include regular inspection of the chamber, door seals and all gauges and controls by qualified personnel.
2. The steam should be saturated and free from corrosion inhibitors or other chemicals, which could contaminate the items being sterilized.
3. All materials to be autoclaved should be in containers that allow ready removal of air and permit good heat penetration; the chamber should not be tightly packed or steam will not reach the load evenly.
4. For autoclaves without an interlocking safety device that prevents the door being opened when the chamber is pressurized, the main steam valve should be closed and the temperature allowed to fall below 80 °C before the door is opened.
5. Operators should wear suitable gloves and visors for protection when opening the autoclave, even when the temperature has fallen below 80 °C.
6. In any routine monitoring of autoclave performance, biological indicators or thermocouples should be placed at the centre of each load. Regular monitoring with thermocouples and recording devices in a "worst case" load is highly desirable to determine proper operating cycles.
7. The drain screen filter of the chamber (if available) should be removed and cleaned daily.
8. Care should be taken to ensure that the relief valves of pressure cooker autoclaves do not become blocked by paper, etc. in the load.

## Incineration

Incineration is useful for disposing of animal carcasses as well as anatomical and other laboratory waste with or without prior decontamination (see section on Contaminated (infectious) materials for disposal in Chapter 3). Incineration of infectious materials is an alternative to autoclaving only if the incinerator is under laboratory control, and it is provided with an efficient means of temperature control and a secondary burning chamber.

Many incinerators, especially those with a single combustion chamber, are unsatisfactory for dealing with infectious materials, animal carcasses and plastics. Such materials may not be completely destroyed and the effluent from the chimney may pollute the atmosphere with microorganisms, toxic chemicals and smoke. However, there are many satisfactory configurations for combustion chambers. Ideally the temperature in the primary chamber should be at least 800 °C and that in the secondary chamber at least 1000 °C. Materials for incineration, even with prior decontamination, should be transported to the incinerator in bags, preferably plastic. Incinerator attendants should receive proper instructions about loading and temperature control. It should also be noted that the efficient operation of an incinerator depends heavily on the right mix of materials in the waste being treated.

There are on-going concerns regarding the possible negative environmental effects of existing or proposed incinerators, and efforts continue to make incinerators more environmentally friendly and energy efficient.

## Disposal

The disposal of laboratory and medical waste is subject to various regional, national and international regulations and the latest versions of such relevant documents must be consulted before designing and implementing a programme for handling, transportation and disposal of biohazardous waste. In general, ash from incinerators may be handled as normal domestic waste and removed by local authorities. Autoclaved waste may be disposed of by off-site incineration or in licensed landfill sites (see section on Contaminated (infectious) materials for disposal in Chapter 3).

## Decontamination of prion-containing materials

Prions, also referred to as “unconventional” infectious agents or “agents of transmissible spongiform encephalopathies”, are believed to contain protein only. As mentioned previously, they can cause Creutzfeldt-Jakob disease in humans, scrapie in sheep, bovine spongiform encephalopathy in cattle, etc. These infectious agents are unusually resistant to inactivation by most physical and chemical agents and materials suspected of containing them require special processing before reuse or disposal.

To date, available data indicate that prions can be inactivated by a solution of 2 mol/l sodium hydroxide (NaOH) containing 4.0 mol/l guanidinium hydrochloride ( $\text{HNC}(\text{NH}_2)_2 \cdot \text{HCl}$ ) or guanidinium isocyanate ( $\text{HNC}(\text{NH}_2)_2 \cdot \text{HNCO}$ ) and sodium hypochlorite ( $\text{NaOCl}$ ) ( $\geq 2\%$  available chlorine) followed by steam autoclaving at 132 °C for 4.5 h.

Incineration is also an effective means of dealing with prion-contaminated materials (see section on Precautions with materials that may contain “unconventional” agents in Chapter 10).

## Summary

Proper use of chemical germicides and autoclaves will contribute to workplace safety while reducing the risk from infectious agents. As far as possible, the number of germicidal chemicals to be used should be limited, not only for economic reasons and better inventory control but also to avoid the loading of the environment with potentially harmful chemicals.

There is much effort under way to make the chemical and physical means of inactivating microorganisms in laboratories better and safer, with newer forms of sterilization and innovative formulations of chemical germicides. At the same time, better methods for testing and validating the claims of products sold for microbial decontamination are being developed. It is therefore important that those designing laboratories and biosafety procedures to be used in them refer to the latest versions of national/international standards and guidelines in this regard.

For further information see references 13 and 29-40.

## **PART IV**

### **Chemical, fire and electrical safety**

*interim guidelines*

interim guidelines

## 15. Hazardous chemicals

Workers in microbiological laboratories are exposed to chemical hazards as well as to pathogenic microorganisms. It is therefore vital that they have proper knowledge of the toxic effects of these chemicals, the routes of exposure, and the hazards that may be associated with their handling and storage. Material safety data sheets (MSDS), which describe the hazards associated with the use of a given chemical, are available from the manufacturer, and should be made available in laboratories where these chemicals are used, e.g. as part of a safety or operations manual.

### Definitions and classifications

Hazardous chemicals are often defined and classified according to regulations written for the transport of dangerous goods or by the hazards and degrees of danger they present. They may be listed by their degree of reactivity, instability, fire or health hazard or by toxic effects.

### Routes of exposure

Exposure to hazardous chemicals may occur in several ways:

|                            |  |
|----------------------------|--|
| <b>Inhalation</b>          | Chemicals may cause irritation, sensitization, allergic reactions, respiratory disease or cancer.          |
| <b>Contact</b>             | Contact with skin may cause chemical burns, conjunctivitis of the eyes, or systemic poisoning.             |
| <b>Ingestion</b>           | Hazardous chemicals may be accidentally swallowed via mouth pipetting, or contamination of food or drinks. |
| <b>Through broken skin</b> | Hazardous chemicals may enter the body via cuts, abrasions or needle-sticks.                               |

### Storage of chemicals

Only minimum amounts of the chemicals listed below should be stored in the laboratory for daily use. Bulk stocks should be kept in specially designated rooms or buildings, which should have concrete floors with sills at doorways to retain spills. Flammable substances should be stored separately in buildings that are some distance from any others. To avoid ignition of flammable and explosive vapours by the sparking of electrical contacts, light switches for these stores should be on the outside of the building and the lights themselves should be in bulkheads.

**Chemicals should not be stored in alphabetical order.** Otherwise incompatible chemicals (see below) may be in close proximity and some hazardous chemicals may be on high shelves. All large bottles and all bottles containing strong acids and alkalis should be at floor level and in drip trays. Bottle carriers and siphoning devices for filling bottles from bulk containers should be provided. Stepladders should be provided where there are high shelves.

### Incompatible chemicals

Many common laboratory chemicals react in a dangerous manner if they come into contact with one another. Some such incompatible chemicals are listed below.

*Acetic acid* – with chromic acid, nitric acid, hydroxyl compounds, ethylene glycol, perchloric acid, peroxides and permanganates.

*Acetone* – with concentrated sulfuric and nitric acid mixtures.

*Acetylene* – with copper (tubing), halogens, silver, mercury and their compounds.

*Alkali metals* – with water, carbon dioxide, carbon tetrachloride and other chlorinated hydrocarbons.

*Ammonia, anhydrous* – with mercury, halogens, calcium hypochlorite and hydrogen fluoride.  
*Ammonium nitrate* – with acids, metallic powders, flammable liquids, chlorates, nitrites, sulfur and finely divided organic or combustible compounds.  
*Aniline* – with nitric acid and hydrogen peroxide.  
*Bromine* – with ammonia, acetylene, butadiene, butane, hydrogen, sodium carbide, turpentine and finely divided metals  
*Carbon, activated* – with calcium hypochlorite and all oxidizing agents.  
*Chlorates* – with ammonium salts, acids, metal powders, sulfur and finely divided organic or combustible compounds.  
*Chlorine* – with ammonia, acetylene, butadiene, benzene and other petroleum fractions, hydrogen, sodium carbide, turpentine and finely divided metals.  
*Chlorine dioxide* – with ammonia, methane, phosphine and hydrogen sulfide.  
*Chromic acid* – with acetic acid, naphthalene, camphor, alcohol, glycerol, turpentine and other flammable liquids.  
*Copper* – with acetylene, azides and hydrogen peroxide.  
*Cyanides* – with acids.  
*Flammable liquids* – with ammonium nitrate, chromic acid, hydrogen peroxide, nitric acid, sodium peroxide and halogens.  
*Hydrocarbons* – with fluorine, chlorine, bromine, chromic acid and sodium peroxide.  
*Hydrogen peroxide* – with chromium, copper, iron, most other metals or their salts, flammable liquids and other combustible products, aniline and nitromethane.  
*Hydrogen sulfide* – with fuming nitric acid and oxidizing gases.  
*Iodine* – with acetylene and ammonia.  
*Mercury* – with acetylene, fulminic acid and ammonia.  
*Nitric acid* – with acetic acid, chromic acid, hydrocyanic acid, aniline, carbon, hydrogen sulfide, fluids, gases and other substances that are readily nitrated.  
*Oxygen* – with oils, greases, hydrogen and flammable liquids, solids and gases.  
*Oxalic acid* – with silver and mercury.  
*Perchloric acid* – with acetic anhydride, bismuth and its alloys, alcohol, paper, wood and other organic materials.  
*Phosphorus pentoxide* – with water.  
*Potassium permanganate* – with glycerol, ethylene glycol, benzaldehyde and sulfuric acid  
*Silver* – with acetylene, oxalic acid, tartaric acid and ammonium compounds.  
*Sodium* – with carbon tetrachloride, carbon dioxide and water.  
*Sodium azide* – with lead, copper and other metals. This compound is commonly used as a preservative but forms unstable, explosive compounds with metals. If it is flushed down sinks, the metal traps and pipes may explode when worked on by a plumber.  
*Sodium peroxide* – with any oxidizable substance, e.g. methanol, glacial acetic acid, acetic anhydride, benzaldehyde, carbon disulfide, glycerol, ethyl acetate and furfural  
*Sulfuric acid* – with chlorates, perchlorates, permanganates and water.

## General rules

Substances in the left-hand column below should be stored and handled so that they cannot accidentally come into contact with the corresponding substances in the right-hand column.

|   |  |
|---|--|
| Alkali metals, e.g. sodium, potassium, caesium and lithium          | Carbon dioxide, chlorinated hydrocarbons, water                            |
| Halogens  | Ammonia, acetylene, hydrocarbons   |
| Acetic acid, hydrogen sulfide, aniline, hydrocarbons, sulfuric acid | Oxidizing agents, e.g. chromic acid, nitric acid, peroxides, permanganates |

## Toxic effects of chemicals

It is well known that some chemicals adversely affect the health of those who handle them or inhale their vapours. Apart from overt poisons, a number of chemicals are known to have various toxic effects. The respiratory system, blood, lungs, liver, kidneys and the gastrointestinal system, as well as other organs



and tissues may be adversely affected or seriously damaged. Some chemicals are known to be carcinogenic or teratogenic.

Some solvent vapours are toxic when inhaled. Apart from the more serious effects noted above, exposure may result in impairments that show no immediate discernible effects on health, but can include lack of coordination, drowsiness and similar symptoms, leading to an increased proneness to accidents.

Prolonged or repeated exposure to the liquid phase of many organic solvents can result in skin damage. This may be due to a defatting effect, but allergic and corrosive symptoms may also arise.

Table 11 lists the reported adverse health effects of some common laboratory chemicals.

**Table 11. Adverse health effects of some laboratory chemicals**

| Chemical  | Reported effects  |  |
|---|---|--|
|   | Acute   | Chronic  |
| Acetaldehyde (acetic aldehyde; ethanal)             | Eye and respiratory tract irritation; narcosis                              | Bronchitis; liver damage                               |
| Acetic anhydride (acetyl oxide; ethanoic anhydride) | Strong eye and upper respiratory tract irritation; corrosive action         |  |
| Acetone (dimethyl ketone; 2-propanone)              | Slight eye, nose and throat irritation; narcosis                            |  |
| Acetonitrile (methyl cyanide)                       | Respiratory irritation; cyanide poisoning                                   |  |
| Acrolein  | Lacrimation; respiratory irritation   |  |
| Ammonia   | Eye irritation  | Pulmonary oedema                                       |
| Aniline (aminobenzene; phenylamine)                 | Cyanosis due to methaemoglobinaemia; slight narcosis; respiratory paralysis |  |
| Benzene   | Narcosis  | Leukaemia; liver damage; aplastic anaemia              |
| Benzidine   | Abdominal pain; nausea; skin irritation                                     | Carcinogenesis   |
| Carbon tetrachloride (tetrachloromethane)           | Headache; nausea; slight jaundice; loss of appetite; narcosis               | Liver and kidney damage; gastrointestinal disturbances |
| Chloroform (trichloromethane)                       | Headache; nausea; slight jaundice; loss of appetite; narcosis               |  |
| Cyanogen bromide                                    | Abdominal pain; nausea; diarrhoea; blurred vision                           | Pulmonary oedema                                       |
| Cytochalasin  | –   | Mutagenesis  |
| Diethyl ether                                       | Vomiting; eye irritation  | Addictive  |
| Dioxane   | Narcosis  | Liver and kidney damage; carcinogenesis                |
| Formaldehyde (formalin)                             | Respiratory, skin and mucous membrane irritation                            | Pulmonary oedema                                       |
| Glutaral  | Respiratory and mucous membrane irritation                                  |  |
| Mercury   | Vomiting; diarrhoea; headache;  | Central nervous system disturbance; swollen gums;      |

| Chemical   | Reported effects   |  |
|--|--|--|
|  | Acute  | Chronic  |
|  | nausea; eye pain   | loose teeth  |
| Methanol (methyl alcohol)                          | Narcosis; mucous membrane irritation   | Damage to retina and optic nerve   |
| $\alpha$ -Naphthylamine                            | –  | Suspected carcinogen   |
| $\beta$ -Naphthylamine                             | –  | Carcinogenesis   |
| Nitrobenzene (nitrobenzol)                         | Cyanosis due to methaemoglobinaemia; slight narcosis                             | Anaemia; reduced blood pressure; methaemoglobinaemia with cyanosis; bladder irritation; liver damage |
| Phenol   | Abdominal pain; vomiting; diarrhoea; skin irritation; eye pain; corrosive action | Central nervous system disturbance; coma   |
| Pyridine   | Liver and kidney damage  | Neurotoxicity  |
| Selenium   | Burning skin; eye pain; cough  | Central nervous system disturbance; teratogenesis  |
| Tetrahydrofuran (diethyl oxide; tetramethyl oxide) | Narcosis; liver and kidney damage; eye and respiratory irritation                | –  |
| Thallium   | Abdominal pain; vomiting; nausea; diarrhoea                                      | Neuropathy; visual problems; muscle weakness; ataxia   |
| o-Tolidine   |  | Carcinogenesis   |
| Toluene (methyl benzene; phenyl methane; toluol)   | Narcosis   | Nonspecific neurological impairment; addiction possible  |
| Trichloroethylene (ethinyl trichloride)            | Narcosis   | Liver damage; nonspecific neurological impairment  |
| m-Xylene (1,2-dimethylbenzene)                     | Narcosis; headache; dizziness; fatigue; nausea                                   | Nonspecific neurological impairment  |
| o-Xylene (1,3-dimethylbenzene)                     | Narcosis; headache; dizziness; fatigue; nausea                                   | Nonspecific neurological impairment  |
| p-Xylene (1,4-dimethylbenzene)                     | Narcosis; headache; dizziness; fatigue; nausea                                   | Nonspecific neurological impairment  |

## Explosive chemicals

*Azides* should not be allowed to come into contact with copper, e.g. in waste pipes and plumbing. Copper azide will explode violently when subjected even to a mild impact.

*Perchloric acid*, if allowed to dry on woodwork, brickwork or fabric, will explode and cause a fire on impact.

*Picric acid and picrates* are detonated by heat and impact.

## Chemical spillage

Most manufacturers of laboratory chemicals issue charts describing methods for dealing with spillages. Spillage charts and spillage kits are also available commercially. Appropriate charts should be displayed in a prominent position in the laboratory. The following equipment should also be provided:

- protective clothing, e.g. heavy-duty rubber gloves; overshoes or rubber boots; respirators
- scoops and dustpans
- forceps for picking up broken glass
- mops, cloths and paper towels
- buckets
- soda ash (sodium carbonate,  $\text{Na}_2\text{CO}_3$ ) or sodium bicarbonate ( $\text{NaHCO}_3$ ) for neutralizing acids
- sand
- nonflammable detergent.

Spills should be neutralized as follows:

|                               |  |
|-------------------------------|--|
| Acids and corrosive chemicals | With soda ash (sodium carbonate) or sodium bicarbonate |
| Alkalis                       | Cover with dry sand                                    |

The following actions should be taken in the event of a spillage of a dangerous chemical.

1. Notify the biosafety officer and evacuate non-essential personnel from the area.
2. Attend to persons who may have been contaminated.
3. If the spilled material is flammable, extinguish all open flames, turn off gas in the room and adjacent areas, and switch off electrical equipment that may spark.
4. Avoid breathing vapour from spilled material.
5. Establish exhaust ventilation if it is safe to do so.
6. Secure the necessary items (see above) to clean up the spillage.

In the event of a large chemical spillage the room should be evacuated and the windows opened, if possible. If the material spilled is flammable, all open flames in the room concerned and those adjacent should be extinguished and all electrical equipment that may spark switched off.

## Compressed and liquefied gases

Rooms where flammable gas cylinders are used should be identified by warning notices on the doors. Not more than one cylinder of a flammable gas should be in the room at any one time. Spare cylinders should be stored in another building at some distance from the laboratory. This store should be locked and identified by a notice.

Compressed gas cylinders should be securely fixed (e.g. chained) to the wall or a solid bench so that they are not dislodged by natural disasters.

Compressed gas cylinders and liquefied gas containers should not be placed near to radiators, open flames or other heat sources, or sparking electrical equipment, or in direct sunlight.

The main high-pressure valve should be turned off when the equipment is not in use and when the room is unoccupied.

Compressed gas cylinders must be transported with their caps in place and supported on trolleys. Small, single-use gas cylinders must not be incinerated.

For further information see references 41-45.

## 16. Fire in the laboratory

Close cooperation between safety officers and local fire prevention officers is essential. Apart from chemical hazards, the effects of fire on the possible dissemination of infectious material must be considered. This may determine any “burn out” policies (i.e. consideration as to whether it is best to extinguish or contain the fire).

The assistance of local fire prevention officers in the training of laboratory staff in fire prevention, immediate action in case of fire, and the use of fire-fighting equipment is desirable.

Fire warnings, instructions and escape routes should be displayed prominently in each room and in corridors and hallways.

Common causes of fires in laboratories are:

- electrical overloading
- poor electrical maintenance
- excessively long gas tubing and electricity leads
- equipment left switched on unnecessarily
- naked flames
- deteriorated gas tubing
- misuse of matches
- carelessness with flammable materials
- flammable and explosive chemicals stored in ordinary refrigerators.

Fire-fighting equipment should be placed near to the doors of rooms and at strategic points in corridors and hallways (as advised by local fire prevention officers). This equipment should include hoses, buckets (of water and sand), and the following types of fire extinguisher: water (H<sub>2</sub>O), carbon dioxide (CO<sub>2</sub>), “dry powder”, and foam. The shelf-life of these extinguishers should be ascertained and arrangements made for them to be regularly inspected and maintained. Their uses are shown in Table 12.

**Table 12. Types and uses of fire extinguishers**

| Type <sup>a</sup>        | Use for  | Do not use for                                      |
|--------------------------|--|---|
| Water                    | Paper, wood fabric   | Electrical fires, flammable liquids, burning metals |
| CO <sub>2</sub> , powder | Flammable liquids and gases, electrical fires                | Alkali metals, paper                                |
| Dry powder               | Flammable liquids and gases, alkali metals, electrical fires |   |
| Foam                     | Flammable liquids  | Electrical fires                                    |

<sup>a</sup> Water extinguishers are driven by carbon dioxide (CO<sub>2</sub>); care is necessary with CO<sub>2</sub> powder extinguishers as the force of the jet may spread burning materials; rooms should be well ventilated after use of BCF extinguishers.

For further information see reference 42.

## 17. Electrical hazards

Electric shock is life-threatening; electrical faults may cause fires. It is therefore essential that all electrical installations and equipment are inspected and tested regularly, including earthing (grounding), and are maintained by qualified electricians. Laboratory staff should not attempt to service any kind of electrical equipment.

Voltages vary from country to country but even low voltages can be hazardous. Care should always be taken to ensure that fuses of the correct rating are interposed between the equipment and the supply. Circuit breakers and earth fault interrupters should be fitted into laboratory electrical circuits.

**Note.** Circuit breakers do not protect people; they are intended to protect wiring from overheating and hence to prevent fires. Earth fault interrupters are intended to protect people from electric shock.

All laboratory electrical equipment should be earthed, preferably through three-prong plugs. Double-insulated devices, requiring only two-prong plugs, are rare in laboratories, but if present may require separate earthing. An earth-free supply may become live as a result of an undetected fault.

All laboratory electrical equipment should conform to the national electrical safety standard or that of the International Electrotechnical Commission.

Laboratory staff should be made aware of the following hazards:

- wet or moist surfaces near to electrical equipment
- long flexible electrical connecting cables
- poor and perished insulation on cables
- overloading of circuits by use of adapters
- sparking equipment near to flammable substances and vapours
- electrical equipment left switched on and unattended
- use of the wrong type of fire extinguisher (water or foam instead of CO<sub>2</sub>) on electrical fires (see Table 12).

For further information see references 46-48.

## **PART V**

### **Safety organization and training**

*interim guidelines*

## 18. The biosafety officer and safety committee

It is essential that each laboratory organization has a comprehensive safety policy, a safety or operations manual, and a safety implementation programme. The responsibility for this normally rests with the director or head of the institute or laboratory, who may, however, delegate certain duties to a biosafety officer or other specialist officers.

It must be emphasized that laboratory safety is also the responsibility of all supervisors and employees, and that individual workers are responsible for their own safety and that of their colleagues. Employees are expected to perform their work safely and not place themselves or others at risk of injury or illness due to unsafe or unhealthy conditions or actions. Laboratory workers should immediately report unsafe acts or conditions to their supervisors.

Periodic safety audits by external independent consultants or specialists are desirable.

### **Biosafety officer**

Wherever possible a biosafety officer should be appointed to ensure that safety policies and programmes are followed consistently throughout the laboratory. The biosafety officer executes these duties on behalf of the head of the institute or laboratory. In small units, the biosafety officer may be a microbiologist or a member of the technical staff, who may perform these duties on a defined part-time basis. Whatever the degree of involvement in safety work, the person designated should have a sound microbiological laboratory background, be actively involved in the work of the laboratory, and have experience and training in the broader aspects of laboratory safety. He or she should not be an administrator or technician involved in administrative or clerical activities.

The activities of the biosafety officer should include the following.

1. Periodic internal safety audits on technical methods, chemicals, materials and equipment; these audits should also include comprehensive workplace surveys to ensure compliance with appropriate local and national safety and health policies and standards.
2. Discussions of infringements of the safety policy with the appropriate persons.
3. Verification that all members of the staff have received appropriate instruction and that they are aware of all hazards, and that members of the medical, scientific and technical staff are competent to handle infectious materials.
4. Provision of continuing instruction in safety for all personnel.
5. Provision of up-to-date safety literature and information to staff about changes in procedures, technical methods, requirements, and the introduction of new equipment.
6. Investigation of all accidents and incidents involving the possible escape of potentially infected or toxic material, even if there has been no personal injury or exposure, and reporting of the findings and recommendations to the director and safety committee.
7. Giving assistance in following up illnesses or absences among laboratory staff where these absences may be associated with the work and recorded as possible laboratory-acquired infections.
8. Ensuring that decontamination procedures are followed in the event of a spill or other incident involving infectious material; a detailed, written record of such accidents and incidents should be kept in case they may be related at a later date to a laboratory-acquired infection or other condition.
9. Ensuring that used materials are decontaminated, and that infectious wastes are safely disposed of after treatment.
10. Ensuring the disinfection of any apparatus requiring repair or servicing before it is handled by non-laboratory personnel.
11. Establishment of procedures for recording the receipt, movements and disposal of pathogenic material and for notification by any research worker or laboratory of the introduction of infectious materials that are new to the laboratory.
12. Advising the director of the presence of any agents that should be notified to the appropriate local or national authorities and regulatory bodies.

13. Reviewing the safety aspects of all plans, protocols and operating procedures for research work prior to the implementation of these procedures.
14. Institution of a system of "on call" duties to deal with any emergencies that arise outside normal working hours.

## Safety committee

If the institute is large enough, a safety committee should be constituted to recommend a safety policy and to formulate a code of practice or safety or operations manual to serve as the basis of safety practices in the individual laboratories, as advised by the biosafety officer. The safety committee should also periodically review and update the safety policy as necessary.

Safety problems brought to the attention of the biosafety officer, along with information about how they were dealt with, should be presented to the safety committee at regular meetings. Other functions of the committee may include risk assessments of research plans, formulation of new safety policies, and arbitration in disputes over safety matters.

The size and composition of the safety committee will depend on the size and nature of the laboratory, on the work involved, and on the distribution of its work units or areas. The membership of the committee should reflect the diverse occupational areas of the organization. In countries where there is national legislation on health and safety, the composition of safety committees may already be determined. The composition of a basic safety committee may be:

|             |                                       |
|-------------|---------------------------------------|
| Chairperson | Elected by members                    |
| Members     | Biosafety officer                     |
|             | Medical adviser                       |
|             | Veterinarian                          |
|             | Representatives of professional staff |
|             | Representatives of technical staff    |
|             | Representatives of management         |

The safety committee may also include in its membership different departmental and specialist safety officers (e.g. with expertise in radiation protection, industrial safety, fire prevention, etc.) and may at times require advice from independent experts in various associated fields, the local authorities, and national regulatory bodies. Community members may also be helpful if there is a particularly contentious or sensitive protocol under discussion.

## General organization

The size and composition of a safety organization will depend on the requirements of the individual laboratory and, in some cases, national regulations. Obviously, small, individual laboratories will not require an elaborate organizational structure or full-time professional safety staff. In many instances, where small individual institutions or laboratories are engaged in work with microorganisms in Risk Groups 1 and 2, a safety organization can be developed for a group of them. Major biomedical institutions may require a separate safety committee that confines its activities to specialized aspects of its own programme.



## 19. Safety rules for support staff

The safe and optimum operation of a laboratory is dependent to a great extent on the support staff, and it is therefore essential that such personnel should be properly trained for their work.

As engineering, maintenance and cleaning personnel have to enter the premises and interact with the laboratory staff, it is essential that they should perform their duties with due regard for appropriate safety rules. They should apply locally adopted standard operational procedures and should be supervised.

### Engineering and building maintenance services

These services, which are concerned with the maintenance and repair of the structure, facilities and equipment, have important support functions in the safety programme. For routine servicing and maintenance it is not only convenient but also good safety policy to have available skilled engineers and craftsmen who also have some knowledge of the nature of the work of the laboratory. Safety regulations are better understood and observed by such staff; external engineers and others may be unaware of the hazards and limitations that are placed upon them when they are working in a laboratory, and therefore need much closer supervision by laboratory staff.

The testing of certain items of equipment after servicing is best carried out independently by or under the supervision of the biosafety officer, e.g. testing the efficiency of biological safety cabinets after new filters have been fitted, and of other equipment designed to minimize or retain aerosols.

Smaller laboratories or institutions that do not have internal engineering and maintenance services, should establish, well in advance of any emergency, a good relationship with local engineers and builders and familiarize them with the equipment and work of the laboratory.

Engineers and maintenance staff should not enter containment laboratories – Biosafety Level 3 or maximum containment laboratories – Biosafety Level 4, except after clearance by, and under the supervision of, the biosafety officer or the laboratory supervisor.

The staff of large facilities with several laboratories should receive training as outlined below.

### Cleaning (domestic) services

Laboratories should preferably be cleaned by staff who are under the control of the laboratory supervisor and not by contract cleaners or staff responsible to other authorities. This practice fosters a safe, cooperative working relationship between the laboratory and cleaning personnel. In particular it ensures that cleaning staff will not be changed without warning.

In containment laboratories – Biosafety Level 3 and maximum containment laboratories – Biosafety Level 4, the cleaning should preferably be done by the laboratory staff. Otherwise cleaning personnel should work only after clearance by, and under the supervision of, the biosafety officer or the laboratory supervisor.

The staff should receive training as outlined below.

The following rules are designed to aid in the prevention of laboratory-acquired infections in cleaning personnel. Copies should be distributed to staff and posted in prominent positions.

### Safety rules for domestic and cleaning staff

1. Always wear the protective clothing provided in the manner prescribed by the laboratory supervisor.
2. Take the protective clothing off when you leave a laboratory to visit another part of the building. Do not wear protective clothing when visiting the staff room, the toilet or the canteen.
3. Wash your hands often, and always before leaving the laboratory or going to the toilet, or to the staff room.
4. Do not eat or drink, or apply cosmetics in any laboratory. Use the staff room or the toilet.
5. Do not dust or clean any work benches without the permission of the laboratory staff.

6. If you have an accident of any kind, or knock over or break any bottle, tube, jar or piece of equipment, tell the biosafety officer or your supervisor or one of the laboratory staff at once.
7. Do not attempt to clear up after any accident without permission. Do not pick up broken glass with your fingers. Use a dustpan and brush, or forceps. Follow the instructions of senior members of the staff.
8. Do not enter any room that has a “restricted entry” sign on the door (e.g. the biohazard or radiation hazard sign) unless authorized to do so.
9. Do not empty any discard containers in the laboratory unless a label or an instruction says that you may do so.

interim guidelines

## 20. Training programmes

A continuous, on-the-job safety training programme is essential to maintain safety awareness among the laboratory and support staff. Laboratory supervisors, with the assistance of the biosafety officer and other resource persons, play the key role in staff training. The effectiveness of biosafety training, indeed all safety and health training, depends on management commitment, motivational factors, adequate initial job training, good communications, and ultimately the organization's goals and objectives. The following are critical elements for an effective biosafety training programme; in addition to taking account of these elements it is recommended that the developers of any safety training programme become acquainted with the principles of adult learning.

**Needs assessment.** This process includes defining the tasks involved, the order of importance (in terms of frequency, criticality, complexity), and details of the steps necessary to accomplish them.

**Establishing training objectives.** The needs assessment provides the information to establish the objectives of the biosafety training programme. These are observable behaviours that the trainee is expected to demonstrate, on the job, after the training. Objectives may acknowledge the conditions under which certain activities or behaviours are performed and the required level of proficiency.

**Specifying training content and media.** Content is the knowledge or skill that the trainee must master to be able to meet the behavioural objectives. Those individuals who know the job and its demands best usually define the content of the biosafety training programme. Other approaches used may focus on the products of problem-solving exercises, or the design of learning measures to correct mistakes people have made in using a skill. It is not clear that one teaching method (lectures, televised instruction, computer-aided instruction, interactive video, etc.) is superior to another. Much depends on specific training needs, the make-up of the trainee group, etc.

**Accounting for individual learning differences.** Effective training must take into account the characteristics or attributes of the trainees. Individuals and groups may differ in aptitude, literacy, culture, spoken language and pre-training skill levels. How the training programme is viewed by trainees in terms of improving their job performance or personal safety may dictate the approach used. Some individuals are more visual or "hands-on" learners; others learn well from written materials. Any special needs of employees must also be addressed, such as course adaptation for those with hearing impairments.

**Specifying learning conditions.** The instructional event (e.g. training course, videotape, written materials, etc.) should not conflict with, inhibit or be unrelated to mastery of the skill or topic being taught. For example, if the intent of the instruction is to develop capabilities in problem-solving techniques, the instructional approach should stress thinking/reasoning approaches rather than rote memorization. The instruction provided should require productive behaviour and/or appropriate feedback (positive/accurate/credible). In addition, instructional events that provide opportunities for practice under conditions similar to that of the job will enhance the transfer of the skill to the actual job.

**Training evaluation.** This provides information that helps to determine whether the instruction has had the intended effect. Training evaluations generally take four forms:

- measuring the trainees' reaction to the instruction provided
- measuring the trainees' recollection and/or performance
- assessing behavioural change on the job
- measuring tangible results in terms of the organization's objectives or goals.

The most complete evaluation of a training effort involves assessments for each of the four areas. The least efficient method of evaluation is to consider only the trainees' reactions to the instruction as this

may bear little relationship to the extent of actual learning. It should not be used as the sole measurement of training effectiveness.

**Training revision.** Training evaluations rarely indicate that a training programme is a complete success or failure because multiple criteria are used to measure results. Usually the data indicate a better understanding, retention or application of some parts of the course material as compared with others. Variation or gaps in knowledge or the desired competencies resulting from the training effort may reflect the need to consider more training time, alternative instructional techniques, or more capable instructors.

A basic course on good laboratory practice that can be modified to suit the needs and objectives of most laboratories is offered below. This is followed by five example training modules designed for members of the laboratory and support staff. These technical modules can also be adapted locally, based on the needs assessment and learning objectives of a particular laboratory or organization.

## **Basic course: Good laboratory practice (GLP)**

### ***General***

1. Sources of laboratory infections
2. Laboratory hazards:
  - ÷ biological
  - ÷ chemical
  - ÷ physical, including fire and electrical hazards
3. Laboratory workers' rights and duties in relation to safety measures

### ***Preparatory procedures***

1. Access to laboratories
2. Personal hygiene
3. Protective clothing

### ***Experimental procedures***

1. Use of mechanical and other pipetting aids
2. Minimization of aerosol production
3. Proper use of biological safety cabinets
4. Proper use of autoclaves and sterilization equipment
5. Proper use of centrifuges

### ***Emergency procedures***

1. First aid (in laboratories)
2. Spillages and breakages
3. Accidents

### ***General laboratory maintenance***

1. Storage of hazardous materials
2. Transport of hazardous materials
3. Handling and care of laboratory animals
4. Control of arthropods and rodents

### ***Check-out procedures***

1. Disposal of hazardous waste:
  - ÷ sterilization
  - ÷ incineration

2. Decontamination procedures
3. Personal hygiene

## **Module 1 (the core module): Good microbiological technique (GMT)**

This module is for scientists and technical staff who work in basic laboratories – Biosafety Levels 1 and 2. The course outlined below can be covered in one week.

As diagnostic laboratories cannot control the kind of specimens they receive and will almost certainly on occasions be required to handle Risk Group 3 microorganisms, some training with these is also necessary.

### **Course contents**

1. Classification of microorganisms according to Risk Groups on the basis of hazard; how this is applied in different geographical areas
2. Laboratory infections; how they occur and the routes and modes of infection
3. Infections due to known accidents, e.g. accidental inoculation, spillage; prevention or minimization
4. Infections due to airborne infectious particles; how these particles (aerosols) are released
5. Measurement and control of aerosols; reduction of hazards by changing techniques and equipment
6. Protective clothing, face and eye protection, personal hygiene, immunization
7. Biological safety cabinets, Classes I and II only (Class III cabinets are unlikely to be used in these laboratories)
8. Universal precautions (3) for handling blood and body fluids
9. Disposal of infected laboratory waste; principles and use of autoclaves and incinerators
10. Chemical disinfection: limitations and policies
11. The animal house: contamination control
12. Laboratory design: principles for a safe laboratory
13. Chemical and carcinogenic hazards; chemical fume cupboards; hazardous analytical equipment
14. Electrical and fire hazards
15. First aid for laboratory accidents
16. Emergency procedures
17. Mailing and shipping of infectious materials
18. Examination of existing codes of practice: formulation of local programmes; duties of biosafety officers; sources of information
19. How to work without modern facilities

## **Module 2: The safe laboratory environment**

Module 2 is in two parts, one concerned with planning for safety and the other with organization for safety. Both parts are aimed at senior scientific and technical laboratory staff, and at engineering, architectural and administrative staff concerned with construction, maintenance and servicing of the buildings. Discussion documents to be provided are relevant national biosafety guidelines and laboratory planning and construction plans. Two days should be allowed for this course.

### **Course contents: Part 1**

1. Size and distribution of rooms for different purposes; planning and building systems; furniture and permanent equipment
2. Services: water, gas, electricity; alternative arrangements where no public services are available
3. Hygiene facilities: washing, toilets, etc.
4. Ventilation, including that of biological safety cabinets and fume cupboards
5. Waste disposal; contaminated and chemical waste; autoclaves and incinerators
6. Animal houses: planning, containment and control; exclusion of unwanted animals including arthropods
7. Security against vandalism

### **Course contents: Part 2**

1. Duties and functions of safety committees
2. Duties and functions of biosafety officers
3. Medical supervision; immunization programmes
4. Training of staff in outlying districts
5. Consideration of a detailed safety or operations manual and how it may be adapted to local circumstances
6. Safety audits; how they are conducted and what auditors (inspectors) should look for
7. General safety services, e.g. fire precautions
8. Emergency-preparedness plans

### **Module 3: GLP for support staff**

This module, for a one-day course, is for the following groups of laboratory support staff who do not normally have any laboratory training.

Group 1. Domestic staff who: clean the premises; dispose of contaminated and other laboratory waste; wash and prepare glassware and other equipment; prepare and sterilize culture media and reagents.

Group 2. Engineering and maintenance staff who: service laboratory facilities; repair equipment.

Group 3. Staff who: receive and sort pathological material brought to the laboratory; open mail; handle request forms and laboratory records; pack infectious materials for mailing or shipping; drive vehicles that carry infectious materials.

### **Course contents**

1. The nature of microorganisms and how they cause infections (all groups)
2. The work of the laboratory (all groups)
3. How to avoid infection in the laboratory; personal hygiene, protective clothing, eating and drinking; biohazard signs and restricted areas (all groups)
4. Use and limitations of disinfectants (all groups)
5. Operation, control and testing of autoclaves, and incinerators (groups 1 and 2)
6. Hazards of particular equipment, e.g. biological safety cabinets, incubators, refrigerators, homogenizers and centrifuges (group 2)
7. Hazards of internal transport and of receiving specimens. opening mail and handling records; how to pack infectious materials for mailing and shipping; emergency action to be taken in case of accident or spillage before the biosafety officer arrives (group 3)
8. Chemical, physical, mechanical, electrical and biological hazards (all groups)
9. The biosafety officer and his or her duties; explanation of the individual worker's rights and responsibilities according to national and local regulations; need to report accidents and unusual occurrences; local security and fire precautions (all groups)
10. Simple first aid (all groups)

### **Module 4: GLP for safety staff**

This module is intended primarily for biosafety officers but other members of the safety committee should be encouraged to attend. Five days should be allowed for this course.

### **Course contents**

1. Outline of legal requirements for conduct in clinical and research laboratories; national occupational health and safety legislation and examples from other, appropriate countries; responsibilities of employers and employees; position of trade unions
2. Codes of practice and guidelines, safety or operations manuals; the employer's declarations of intent and safety policies; implementation of safety programmes; duties of biosafety officers and safety committees
3. Accident and incident reporting: mechanisms and channels in routine and emergency situations
4. Emergency programmes; preparing protocols for dealing with accidents, spillage, etc.

5. Medical surveillance: documentation of staff; immunization and sickness records; actions if laboratory infection is suspected
6. Staff problems leading to aberrant behaviour and consequent hazards
7. Laboratory and animal house vandalism; security arrangements
8. Laboratory accidents: inoculation, spillage, breakage, equipment-related hazards: centrifuges, homogenizers, pipetting, microbiological manipulations
9. Aerosols: how released (equipment and technique-related); hazards involved; measurement with slit and cascade samplers: theory and practice of HEPA filtration
10. Supervision and instruction of staff in personal hygiene and use of protective clothing
11. Biological safety cabinets: classification, limitations and selective use; installation and testing (biological challenge, chemical smokes); training of users
12. Design and testing of ventilation systems; graduated pressures; effluent control; clean air rooms
13. Principles and application of disinfection and sterilization; kinetics of bacterial destruction; autoclaves and their control; use of thermocouples and indicators (chemical and biological)
14. Chemical and gaseous disinfectants; efficiency testing; disinfection policies; ultraviolet-irradiation
15. Packaging, mailing and shipping of infectious materials; national and international regulations; emergency procedures
16. The animal house: containment and control; isolation from the environment
17. Hazardous chemicals: handling and storage; threshold limit values (or equivalent) and their measurement
18. Radiation hazards: legal requirements and local control
19. Life support apparatus; lock-out procedures; the two-person rule
20. Fire precautions; "burn-out" decisions, i.e. whether to contain or extinguish the fire
21. Emergency preparedness plans
22. Emergency evacuation of staff and animals

## **Module 5: GLP for specialist staff who handle microorganisms in Risk Groups 3 and 4**

This module is for specialized scientific, technical and safety staff who will handle microorganisms in Risk Groups 3 and 4. It is essential that safety personnel are trained up to the level of Module 4 before following this module. Staff who have not received the proper training should not be given responsibility for microorganisms in Risk Groups 3 and 4. The course lasts two to three days.

### **Course contents**

1. Risk Groups 3 and 4 microorganisms: identity, associated diseases; clinical and epidemiological features; natural reservoirs, vectors; modes of spread, prevention and treatment
2. Potential hazards of genetic manipulations and their relation to microorganisms in Risk Groups 3 and 4
3. Levels of containment for Risk Group 3 and 4 microorganisms
4. Classes I and II biological safety cabinets; containment laboratory – Biosafety Level 3 procedures; design of facilities for work with Risk Group 3 microorganisms
5. Class III biological safety cabinets; maximum containment laboratory – Biosafety Level 4 procedures for work with microorganisms in Risk Group 4
6. Specialized facilities for specific pathogens; monitoring of effluents: specialized clothing and hygiene facilities
7. Specialized equipment: Class III biological safety cabinets, testing control, training in use; double-door pass-through autoclaves; warning against full dependence on mechanical equipment that may give a false sense of security
8. Simple maintenance of electrical power, water, pressure equipment, etc. in areas where maintenance staff cannot immediately be admitted
9. Medical supervision; immunization; emergency measures
10. Documentation of activities

For further information see references 49-51.

interim guidelines



## **PART VI**

### **Safety checklist**

*interim guidelines*

interim guidelines

## 21. Safety checklist

This checklist is intended to assist in assessments of the safety status of biomedical laboratories

### Laboratory premises

1. Do the premises meet national and local building requirements, including those relating to flood and earthquake precautions if necessary?
2. Are the premises generally uncluttered and free from obstructions?
3. Are the premises clean?
4. Are there any structural defects in floors, stairways, walls and roofs?
5. Are floors and stairs uniform and slip-resistant?
6. Are there handrails on flights of stairs with more than four risers?
7. Are there guarded rails on floor openings?
8. Is the working space adequate for safe operation?
9. Are the circulation spaces and corridors adequate for the movement of people and large equipment?
10. Are the benches, furniture and fittings in good condition?
11. Are bench surfaces resistant to solvents and corrosive chemicals?
12. Is there a hand-wash basin in each laboratory room?
13. Are the premises constructed and maintained to prevent entry and harbourage of rodents and arthropods?
14. Are all exposed steam and hot water pipes insulated or guarded to protect personnel?
15. Is an independent power support unit provided in case of power breakdown?

### Storage facilities

1. Are storage facilities, shelves, etc., arranged so that stores are secure against sliding, collapse or falls?
2. Are storage facilities kept free from accumulations of rubbish, unwanted materials and objects that present hazards from tripping, fire, explosion and harbourage of pests?

### Sanitation and staff facilities

1. Are the premises maintained in a clean, orderly and sanitary condition?
2. Is drinking-water available?
3. Are clean and adequate toilet (WC) and washing facilities provided separately for male and female staff?
4. Are hot and cold water, soap and towels provided?
5. Are separate changing rooms provided for male and female staff?
6. Is there accommodation (e.g. lockers) for street clothing for individual members of the staff?
7. Is there a staff room for lunch, etc.?
8. Are noise levels acceptable?
9. Is there an adequate organization for the collection and disposal of general household rubbish?

### Heating and ventilation

1. Is there a comfortable working temperature?
2. Are blinds fitted to windows that are exposed to full sunlight?
3. Is the ventilation adequate, e.g. at least six changes of air per hour, especially in rooms that have mechanical ventilation?

4. Are there HEPA filters in the ventilation system?
5. Does mechanical ventilation compromise air flows in and around biological safety cabinets and fume cupboards?

## Lighting

1. Is the general illumination adequate (e.g. 300–400 lx)?
2. Is task (local) lighting provided at work benches?
3. Are there dark or ill-lit corners in rooms and corridors?
4. Are fluorescent lights parallel to the benches?
5. Are fluorescent lights colour-balanced?

## Services

1. Is each laboratory room provided with enough sinks, water, electricity and gas outlets for safe working?
2. Is there an adequate inspection and maintenance programme for fuses, lights, cables, pipes, etc.?
3. Are faults corrected within a reasonable time?
4. Are internal engineering and maintenance services available, with skilled engineers and craftsmen who also have some knowledge of the nature of the work of the laboratory?
5. If no internal engineering and maintenance services are available, have local engineers and builders been contacted and familiarized with the equipment and work of the laboratory?

## Security

1. Is the whole building securely locked when unoccupied?
2. Are doors and windows vandal-proof?
3. Are rooms containing hazardous materials and expensive equipment locked when unoccupied?

## Fire prevention

1. Is there a fire alarm system?
2. Are the fire doors in good order?
3. Is the fire detection system in good working order and regularly tested?
4. Are fire alarm stations accessible?
5. Are all exits marked by proper, illuminated signs?
6. Is access to exits marked where the routes to them are not immediately visible?
7. Are all exits unobstructed and unlocked when the building is occupied?
8. Are any exits obscured by decorations, furniture or equipment?
9. Is access to exits arranged so that it is not necessary to pass through a high-hazard area to escape?
10. Do all exits lead to an open space?
11. Are corridors, aisles and circulation areas clear and unobstructed for movement of staff and fire-fighting equipment?
12. Is all fire-fighting equipment and apparatus easily identified by an appropriate colour code?
13. Are portable fire extinguishers maintained fully charged and in working order, and kept in designated places at all times?
14. Are laboratory rooms with potential fire hazards equipped with appropriate extinguishers and/or fire blankets for emergency use?
15. If flammable liquids and gases are used in any room, is the mechanical ventilation sufficient to remove vapours before they reach a hazardous concentration?

## Flammable liquid storage

1. Is the storage facility for bulk flammable liquids separated from the main building?
2. Is it clearly labelled as a fire-risk area?
3. Does it have a gravity or mechanical exhaust ventilation system that is separate from the main building system?

4. Are the switches for lighting sealed or placed outside the building?
5. Are the light fittings inside sealed to protect against ignition of vapours by sparking?
6. Are flammable liquids stored in proper, ventilated containers that are made of non-combustible materials?
7. Are the contents of all containers correctly described on the labels?
8. Are appropriate fire extinguishers and/or fire blankets placed outside but near to the flammable liquid store?
9. Are "No smoking" signs clearly displayed inside and outside the flammable liquid store?
10. Are only minimum amounts of flammable substances stored in laboratory rooms?
11. Are they stored in properly constructed flammable storage cabinets?
12. Are these cabinets adequately labelled with "Flammable liquid – Fire hazard" signs?

### Electrical hazards

1. Are all new electrical installations and all replacements, modifications or repairs made and maintained in accordance with an electrical safety code?
2. Does the interior wiring have an earthed (grounded) conductor (i.e. a three-wire system)?
3. Are circuit breakers and earth fault interrupters fitted to all laboratory circuits?
4. Do all electrical appliances have testing laboratory approval?
5. Are the flexible connecting cables of all equipment as short as practicable, in good condition, and not frayed, damaged or spliced?
6. Is each electric socket outlet used for only one appliance (no adapters to be used)?

### Compressed and liquefied gases

1. Is each portable gas container legibly marked with its contents and correctly colour-coded?
2. Are compressed-gas cylinders and their high-pressure and reduction valves regularly inspected for safety?
3. Are reduction valves regularly maintained?
4. Is a pressure-relief device connected when a cylinder is in use?
5. Are protection caps in place when cylinders are not in use or are being transported?
6. Are all compressed gas cylinders secured so that they cannot fall, especially in the event of natural disaster?
7. Are cylinders and liquid petroleum gas tanks kept away from sources of heat?

### Personal protection

1. Is protective clothing of an approved design provided for all staff for normal work, e.g. gowns, coveralls, aprons, gloves?
2. Is additional protective clothing provided for work with hazardous chemicals and radioactive and carcinogenic substances e.g. rubber aprons and gloves for chemicals and for dealing with spillages; heat-resistant gloves for unloading autoclaves and ovens.
3. Are safety glasses, goggles and shields (visors) provided?
4. Are there eye-wash stations?
5. Are there emergency showers (drench facilities)?
6. Is radiation protection in accordance with national and international standards, including provision of dosimeters?
7. Are masks available?
8. Are respirators available, regularly cleaned, disinfected, inspected and stored in a clean and sanitary condition?
9. Are appropriate filters provided for the correct types of respirators, e.g. HEPA filters for microorganisms, appropriate filters for gases or particulates?
10. Are respirators fit-tested?

### Health and safety of staff

1. Is there an occupational health service?
2. Are first-aid boxes provided at strategic places?

3. Are qualified first-aiders available?
4. Are such first-aiders trained to deal with emergencies peculiar to the laboratory, e.g. contact with corrosive chemicals, accidental ingestion of poisons and infectious materials?
5. Are non-laboratory workers, e.g. domestic and clerical staff, instructed on the potential hazards of the laboratory and the material it handles?
6. Are notices prominently posted giving clear information about the location of first-aiders, telephone numbers of emergency services, etc.?
7. Are women of childbearing age warned of the consequences of work with certain microorganisms, carcinogens, mutagens and teratogens?
8. Are women of childbearing age told that if they are, or suspect that they are, pregnant they should inform the appropriate member of the medical/scientific staff so that alternative working arrangements may be made for them if necessary?
9. Is there an immunization programme relevant to the work of the laboratory?
10. Are skin tests and/or radiological facilities available for staff who work with tuberculous materials or other materials requiring such measures?
11. Are proper records maintained of illnesses and accidents?
12. Are warning and accident prevention signs used to minimize work hazards?

### Laboratory equipment

1. Is all equipment certified safe for use?
2. Are procedures available for decontaminating equipment prior to maintenance?
3. Are biological safety cabinets and fume cupboards regularly tested and serviced?
4. Are autoclaves and other pressure vessels regularly inspected?
5. Are centrifuge buckets and rotors regularly inspected?
6. Are pipettes used instead of hypodermic needles?
7. Is cracked and chipped glassware always discarded and not reused?
8. Are there safe receptacles for broken glass?
9. Are plastics used instead of glass where feasible?

### Infectious materials

1. Are specimens received in a safe condition?
2. Are records kept of incoming materials?
3. Are specimens unpacked in biological safety cabinets with care and attention to possible breakage and leakage?
4. Are gloves worn for unpacking specimens?
5. Are work benches kept clean and tidy?
6. Do discarded infectious materials, e.g. cultures, accumulate on benches and other places?
7. Are discarded infectious materials removed daily or more often and disposed of safely?
8. Are all members of the staff aware of procedures for dealing with breakage and spillage of cultures and infectious materials?
9. Is the performance of sterilizers checked by chemical, physical and biological indicators?
10. Are centrifuges decontaminated daily?
11. Are sealed buckets provided for centrifuges?
12. Are appropriate disinfectants used correctly?
13. Is there special training for staff who work in containment laboratories – Biosafety Level 3 and maximum containment laboratories – Biosafety Level 4?

### Chemicals and radioactive substances

1. Are incompatible chemicals effectively separated when stored or handled?
2. Are all chemicals correctly labelled with names and warnings?
3. Are chemical hazard warning charts prominently displayed?
4. Are spillage clearance kits provided?
5. Are staff trained to deal with spillages?
6. Are flammable substances correctly and safely stored in minimal amounts in approved cabinets?
7. Are bottle carriers provided?

8. Is a radiation protection officer or reference manual available for consultation?
9. Are proper records maintained of stocks and use of radioactive substances?
10. Are radioactivity screens and bench- $\beta$ -counters provided?

interim guidelines

## References

1. Richmond JY, McKinney RW. *Biosafety in microbiological and biomedical laboratories*, 4th ed. Washington, DC, U.S. Department of Health and Human Services/Centers for Disease Control and Prevention/National Institutes of Health, 1999.
2. Directive 2000/54/EC of the European Parliament and of the Council of 18 September 2000 on the protection of workers from risks related to exposure to biological agents at work. *Official Journal*, 2000, L 262:21-45.
3. Perspectives in Disease Prevention and Health Promotion Update: Universal Precautions for Prevention of Transmission of Human Immunodeficiency Virus, Hepatitis B Virus, and Other Bloodborne Pathogens in Health-Care Settings. *MMWR*, 1988, 37:377-388, <http://www.cdc.gov/mmwr/preview/mmwrhtml/00000039.htm>.
4. *ACGM compendium of guidance - guidance from the Health and Safety Commission's Advisory Committee on Genetic Modification*. London, HSE Books, 2000.
5. European Council. Council Directive 98/81/EC of 26 October 1998 amending Directive 90/219/EEC on the contained use of genetically modified microorganisms. *Official Journal*, 1998, L330:13-31.
6. Hunt GJ, Tabachnick WJ. Handling small arbovirus vectors safely during biosafety level 3 containment: *Culicoides variipennis sonorensis* (Diptera: Ceratopogonidae) and exotic bluetongue viruses. *Journal of Medical Entomology*, 1996, 33:271-277.
7. The Subcommittee on arthropod-borne viruses. Laboratory safety for arboviruses and certain other viruses of vertebrates. *American Journal of Tropical and Medical Hygiene*, 1980, 29:1357-1381.
8. National Research Council. *Occupational health and safety in the care and use of research animals*. Washington, DC, National Academy Press, 1997.
9. Richmond JY, Quimby F. Considerations for working safely with infectious disease agents in research animals. In: Zak O, Sande MA, eds. *Handbook of animal models of infection*. London, Academic Press, 1999:69-74.
10. National Sanitation Foundation. *Class II (laminar flow) biohazard cabinetry*. Ann Arbor, MI, 2002 (NSF/ANSI 49-2002).
11. Richmond JY, McKinney RW. *Primary containment for biohazards: selection, installation and use of biological safety cabinets*, 2nd ed. Washington, DC, U.S. Department of Health and Human Services/Centers for Disease Control and Prevention/National Institutes of Health, 2000.
12. Collins CH, Kennedy DA. *Laboratory acquired infections: history, incidence, causes and prevention*, 4th ed. Oxford, Butterworth-Heinemann, 1999.
13. Health Canada. *Laboratory biosafety manual*, 2nd ed. Ottawa, Minister of Supply and Services Canada, 1996.
14. British Standards Institution. *Microbiological safety cabinets. Recommendations for information to be exchanged between purchaser, vendor and installer and recommendations for installation*. London, 1992 (Standard BS 5726-2:1992).



15. British Standards Institution. *Microbiological safety cabinets. Recommendations for selection, use and maintenance*. London, 1992 (Standard BS 5726-4:1992).
16. Canadian Standards Association. *Biological containment cabinets (Class I and II): installation and field testing*. Toronto, 1995 (Standard Z316.3-95 (R2000)).
17. Standards Australia. *Biological safety cabinets - biological safety cabinets (Class I) for personnel and environment protection*. Sydney, Standards Australia International, 1994 (Standard AS 2252.1-1994).
18. Standards Australia. *Biological safety cabinets - laminar flow biological safety cabinets (Class II) for personnel, environment and product protection*. Sydney, Standards Australia International, 1994 (Standard AS 2252.2-1994).
19. Standards Australia/ Standards New Zealand. *Biological safety cabinets - installation and use*. Sydney, Standards Australia International, 2000 (Standard AS/NZS 2647:2000).
20. Standards Australia/ Standards New Zealand. *Safety in laboratories - microbiological aspects and containment facilities*. Sydney, Standards Australia International, 2002 (Standard AS/NZS 2243.3:2002).
21. Advisory Committee on Dangerous Pathogens. *Guidance on the use, testing and maintenance of laboratory and animal flexible film isolators*. London, Health and Safety Executive, 1990.
22. Safar J et al. Prions. In: Richmond JY, McKinney RW, eds. *Biosafety in microbiological and biomedical laboratories*, 4th ed. Washington, DC, U.S. Department of Health and Human Services, 1999:134-143.
23. Bellinger-Kawahara C et al. Purified scrapie prions resist inactivation by UV irradiation. *Journal of Virology*, 1987, 61:159-166.
24. Berg P et al. Asilomar conference on recombinant DNA molecules. *Science*, 1975, 188:991-994.
25. Toloza EM et al. In vivo cancer gene therapy with a recombinant interleukin-2 adenovirus vector. *Cancer Gene Therapy*, 1996, 3:11-17.
26. O'Malley BW Jr et al. Limitations of adenovirus-mediated interleukin-2 gene therapy for oral cancer. *Laryngoscope*, 1999, 109:389-395.
27. World Health Organization. Maintenance and distribution of transgenic mice susceptible to human viruses. Memorandum from a WHO meeting. *Bulletin of the World Health Organization*, 1993, 71:497-502.
28. Health Services Advisory Committee. *Safe working and the prevention of infection in clinical laboratories*. London, HSE Books, 1991.
29. Ascenzi JM. *Handbook of disinfectants and antiseptics*. New York, NY, Marcel Dekker, 1996.
30. Block SS. *Disinfection, sterilization & preservation*, 5th ed. Philadelphia, PA, Lippincott Williams & Wilkins, 2001.
31. Russell AD, Hugo WB, Ayliffe GAJ. *Disinfection, preservation and sterilization*, 3rd ed. Oxford, Blackwell Scientific, 1999.
32. Rutala WA. APIC guideline for selection and use of disinfectants. *American Journal of Infection Control*, 1996, 24:313-342.

33. Sattar SA, Springthorpe VS, Rochon M. A product based on accelerated and stabilized hydrogen peroxide: evidence for broad-spectrum germicidal activity. *Canadian Journal of Infection Control*, 1998, 13:123-130.
34. Schneider PM. Emerging low temperature sterilization technologies. In: Rutala WA, eds. *Disinfection & sterilization in health care*. Champlain, NY, Polyscience, 1997:79-92.
35. Springthorpe VS. New chemical germicides. In: Rutala WA, eds. *Disinfection & sterilization in health care*. Champlain, NY, Polyscience, 1997:273-280.
36. Steelman VM. Activity of sterilization processes and disinfectants against prions. In: Rutala WA, eds. *Disinfection & sterilization in health care*. Champlain, NY, Polyscience, 1997:255-271.
37. Taylor DM. Transmissible degenerative encephalopathies: inactivation of the unconventional causal agents. In: Russell AD, Hugo WB, Ayliffe GAJ, eds. *Disinfection, preservation and sterilization*, 3rd ed. Oxford, Blackwell Scientific, 1999:222-236.
38. Health Canada. *Infection control guidelines for hand washing, cleaning, disinfection and sterilization in health care*, 2nd ed. Ottawa, Laboratory Centre for Disease Control, Health Canada, 1998.
39. Springthorpe VS, Sattar SA. Chemical disinfection of virus-contaminated surfaces. *CRC Critical Reviews in Environmental Control*, 1990, 20:169-229.
40. Sattar SA et al. The inactivation of HIV: an update. *Reviews in Medical Microbiology*, 1994, 5:139-150.
41. Eggimann W, Bastian C. Safety in handling chemical substances at a global level. *Immunological Investigations*, 1997, 24:25-48.
42. Furr AK. *CRC handbook of laboratory safety*, 5th ed. Boca Raton, FL, CRC Press LLC, 2000.
43. Lenga RE. *The Sigma-Aldrich Library of Chemical Safety Data*, 2nd ed. Milwaukee, WI, Aldrich Chemical Company, 1988.
44. Lewis RJ. *Sax's dangerous properties of industrial materials*, 10th ed. Toronto, John Wiley and Sons, 1999.
45. *Safety in health-care laboratories*. Geneva, World Health Organization, 1997 (unpublished document WHO/LAB/97.1; available on request from Division of Blood Safety and Clinical Technology, World Health Organization, 1211 Geneva 27, Switzerland, [http://whqlibdoc.who.int/hq/1997/WHO\\_LAB\\_97.1.pdf](http://whqlibdoc.who.int/hq/1997/WHO_LAB_97.1.pdf)).
46. International Electrotechnical Commission. *Fundamental aspects of safety standards for medical electrical equipment*. Geneva, 1994 (IEC/TR3 60513 (1994-01)).
47. International Electrotechnical Commission. *Medical electrical equipment - Part 1-1: General requirements for safety - Collateral standard: Safety requirements for medical electrical systems*. Geneva, 2000 (IEC 60601-1-1 (2000-12)).
48. International Electrotechnical Commission. *Medical electrical equipment - Part 1-2: General requirements for safety - Collateral standard: Electromagnetic compatibility - Requirements and tests*. Geneva, 2000 (IEC 60601-1-2 (2001-09)).
49. Cohen A and Colligan MJ. *Assessing occupational safety and health training*. Cincinnati, OH, National Institute for Occupational Safety and Health, 1998 (DHHS (NIOSH) Publication No. 98-145).

50. Goldstein IL, Buxton VM. Training and human performance. In: Alluisi EA, Fleishman EA, eds. *Human performance and productivity: stress and performance effectiveness, Vol. 3*. Hillsdale, NJ, Lawrence Erlbaum Associates, 1982.
51. Kroehnert G. *Basic training for trainers: a handbook for new trainers*. Sidney, McGraw-Hill, 1995.

interim guidelines

## ANNEX 1

### Immunization of staff

1. It is recommended that all laboratory personnel receive protective immunization against the following diseases: diphtheria, hepatitis B, measles, mumps, poliomyelitis, rubella, tetanus, tuberculosis<sup>1</sup>, typhoid fever. Some workers may have been immunized during childhood but documentary evidence of current protection should be obtained.  
**Note.** BCG does not appear to give as much protection against tuberculosis in some parts of the world, e.g. the Indian subcontinent, as in others; see *BCG vaccination policies: report of a WHO Study Group*. Geneva, World Health Organization, 1980 (WHO Technical Report Series, No. 652), and Fine PE et al. *Issues relating to the use of BCG in immunization programmes. A discussion document*. Geneva, World Health Organization, 1999 (unpublished document WHO/V&B/99.23)<sup>2</sup>.
2. All persons who work with or who handle animals infected with the following agents should be given the appropriate vaccine or toxoid, and facilities for specific clinical case management following accidental infections should be available: *Bacillus anthracis*, *Clostridium botulinum*, *Francisella tularensis* type A, *Haemophilus influenzae*, Japanese B encephalitis virus, *Mycobacterium leprae*, *Neisseria meningitidis*, *Yersinia pestis*, hepatitis A virus, influenza virus, louping ill virus<sup>3</sup>, rabies virus, Rift Valley fever virus, tick-borne encephalitis viruses<sup>3</sup> (Absettarov virus, Hanzalova virus and Omsk haemorrhagic fever virus), varicella-zoster virus, Venezuelan equine encephalomyelitis virus, yellow fever virus. Vaccinia vaccine is recommended for persons who work with orthopoxviruses. Other vaccines are available and may be indicated in specific circumstances for laboratory workers at high risk.

---

<sup>1</sup> Caused by *Mycobacterium tuberculosis*, *M. bovis* and *M. africanum*.

<sup>2</sup> Obtainable on request from Department of Vaccines and Other Biologicals, World Health Organization, 1211 Geneva 27, Switzerland (<http://www.who.int/gpv-documents/>).

<sup>3</sup> These viruses are antigenically very similar; immunization against one is expected to give protection against others.

## ANNEX 2

# WHO Biosafety Collaborating Centres

Information on the availability of training courses, aids and materials may be obtained by writing to any of the following:

- ÷ Biosafety Programme, Department of Communicable Disease Surveillance and Response, CSR Office in Lyon, World Health Organization, 58 Avenue Debourg, 69007 Lyon, France. <http://www.who.int/emc/>
- ÷ WHO Collaborating Centre for Biological Safety, Swedish Institute for Infectious Disease Control, Nobels Väg 18, S-171 82 Solna, Sweden. <http://www.smittskyddsinstitutet.se/English/english.htm>
- ÷ WHO Collaborating Centre on Biosafety Technology and Consultative Services, Office of Biosafety, Health Canada, Tunney's Pasture 0700A1, Ottawa, Ontario, Canada K1A 0L2. <http://www.hc-sc.gc.ca/hpb/lcdc/biosafte>
- ÷ WHO Collaborating Centre for Applied Biosafety Programmes and Training, Office of Health and Safety, Centers for Disease Control and Prevention, 1600 Clifton Road, Mailstop F05, Atlanta, GA 30333, USA. <http://www.cdc.gov/>
- ÷ WHO Collaborating Centre for Applied Biosafety Programmes and Research, Occupational Safety and Health Branch, Division of Safety, National Institutes of Health, 13/3K04 13 South Drive MSC 5760, Bethesda, MD 20892-5760, USA. <http://www.nih.gov/>
- ÷ WHO Collaborating Centre for Biosafety, Victorian Infectious Diseases Reference Laboratory, 10 Wreckyn St, Nth Melbourne, Victoria 3051, Australia. Postal address: Locked Bag 815, PO Carlton Sth, Victoria 3053, Australia. <http://www.vidri.org.au/>